

SYSTEM REFERENCE INCLUDES: Outdoor Unit + Indoor Units + One Remote Controller, + Pipe Kit					FDT	FDTC	FDE	FDUM	FDK
					CASSETTE	COMPACT CASSETTE	CEILING MOUNTED	DUCTED	WALL MOUNTED
OUTDOOR UNIT INVERTER					INDOOR UNIT				
OUTDOOR UNIT	COOLING range kW	HEATING range kW	Power supply	REF:	INVERTER	INVERTER	INVERTER	INVERTER	INVERTER
FDC71VN	3.2 to 8.0	3.6 to 9.0	1 ph 16A	2 x 40	M2FDT40VN	M2FDTC40VN	M2FDE40VN	FDUMA units include discharge spigots & condensate lift pump.	APPLICATION tba
	TWIN								
FDC100VN	6.1 to 11.2	5.8 to 12.5	1 ph* 20A	2 x 50	M2FDT50VN	M2FDTC50VN	M2FDE50VN	M2FDUM50VN	APPLICATION tba
	TWIN								
FDC125VN	6.5 to 14.0	6.2 to 16.0	1 ph* 25A	2 x 60	M2FDT60VN	N/A	M2FDE60VN	M2FDUM60VN	APPLICATION tba
	TWIN								
FDC140VN	6.7 to 14.8	6.3 to 16.8	1 ph* 30A	2 x 71	M2FDT71VN	N/A	M2FDE71VN	M2FDUM71VN	N/A
	TWIN								
FDC200VS	7.0 to 22.4	7.6 to 25.0	3 ph 15A/ph	2 x 100	M2FDT100VS	N/A	M2FDE100VS	M2FDUM100VS	N/A
	TWIN								
	7.0 to 22.4	7.6 to 25.0	3 ph 15A/ph	3 x 71	M3FDT71VN	N/A	M3FDE71VS	M3FDUM71VS	N/A
	TRIPLE								
	7.0 to 22.4	7.6 to 25.0	3 ph 15A/ph	4 x 50	M4FDT50VS	M4FDTC50VS	M4FDE50VS	M4FDUM50VS	APPLICATION tba
	QUAD								
FDC250VS	10.6 to 28.0	9.5 to 31.5	3 ph 20A/ph	2 x 125	M2FDT125VS	N/A	M2FDE125VS	M2FDUM125VS	N/A
	TWIN								
	10.6 to 28.0	9.5 to 31.5	3 ph 20A/ph	2 x 71 1 x 100	M3FDT71-100VS	N/A	M3FDE71-100VS	M3FDUM71-100VS	N/A
	TRIPLE								
	10.6 to 28.0	9.5 to 31.5	3 ph 20A/ph	4 x 60	M4FDT60VS	N/A	M4FDE60VS	M4FDUM60VS	APPLICATION tba
	QUAD								

Cooling Nom: 27°Cdb/19°Cwb, Amb: 35°C UK Cooling: I/d: 23°Cdb/16°Cwb, Amb: 30°C Heating: I/d: 20°Cdb, Amb: 7°Cdb/6°Cwb

\*3PH UNITS ALSO AVAILABLE 100, 125 & 140

N.B. Wall units are not suitable for mix-match with other indoor styles.

Mitsubishi Heavy Industries has further extended its development in world leading technology applied to high efficiency air conditioning and heat pump systems

### FDC INVERTER Multi Systems

Cooling Range: 8.0 - 28kW

Heating Range: 9.0 - 31.5kW



Ideal for cooling and heating open plan areas from 20m<sup>2</sup> to 600m<sup>2</sup>

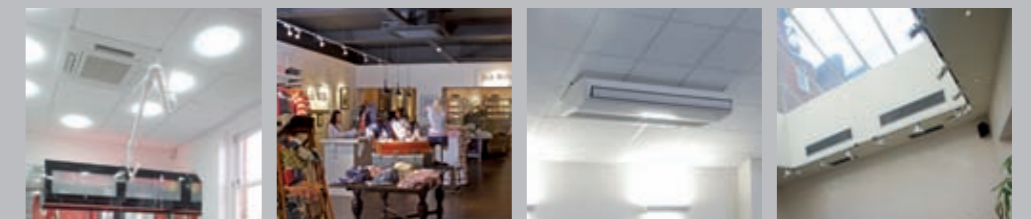

FITNESS GYMS • RETAIL STORES • OPEN PLAN OFFICES • CONFERENCE ROOMS • LARGE RESTAURANTS

The ADVANCED FDC Multi System is a high specification product, with energy saving INVERTER technology, extended pipe runs, and sophisticated operation and service control functions. The systems are available in TWIN, TRIPLE and QUAD format.

- Simple operation - all units on a system are connected to one controller and will operate in the same mode ie. cooling, heating or fan only
- 7-day/24-hr Programmable Timer - included in standard wired controller
- Mitsubishi INVERTER Scroll Compressors resulting in significant savings in running costs
- Up to 70m pipe runs
- Compact Outdoor Units with side-blow fans, have now been introduced, with lower sound levels and smaller physical size, ideal for installation in restricted locations



Wiring Arrangement and Master/Slave settings for Multi Systems

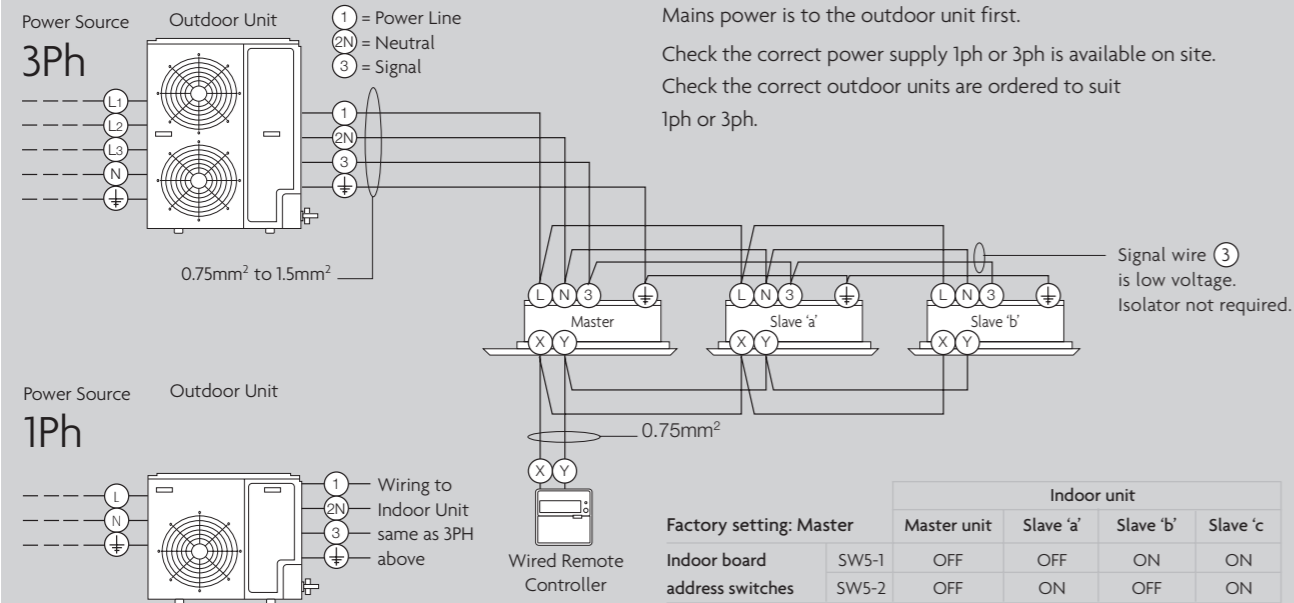

Power Supplies & Operating Current - Outdoor Units

Outdoor Unit	Power Supply Outdoor Unit	Operating to Current (clg.)
FDC71VN	16A	9.8A
FDC100VN	1ph 20A	12.3A
FDC125VN	1ph 25A	18.3A
FDC140VN	1ph 30A	20.4A
FDC200VS	3ph 15A/ph	9.1A/ph
FDC250VS	3ph 20A/ph	12.7A/ph

Indoor Units - Operating Current

Indoor Unit	FDT	FDE	FDUM	FDK*
40	0.3A	0.2A		0.2A
50	0.3A	0.2A	0.9A	0.2A
60	0.3A	0.4A	1.0A	0.2A
71	0.3A	0.4A	1.3A	
100	0.6A	0.5A	1.7A	
125	0.7A	0.6A	2.0A	

\* application for FDK to be advised

Indoor Unit Address

Indoor units connected to FD Multi Systems are required to be addressed, to enable the controls to recognise which units are connected to each system. Each system comprises one master indoor unit and one, two or three slave indoor units.

Group Control

Where Multi Systems are controlled on a Group arrangement (up to 16 systems) using a single remote controller, it is necessary to adjust SW2 so each individual Multi System has indoor units with the same address number, ie. 0-0-0, 1-1-1, 2-2-2, etc.

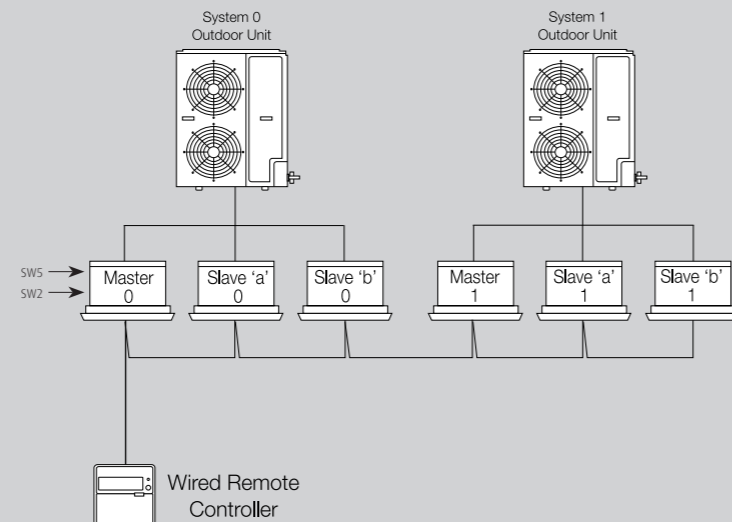

The Master/Slave addresses must also be adjusted using SW5 - see above

Pipe Length Limitations

Height Difference (all systems)

Outdoor unit above max. height difference is 30m  
Outdoor unit below max. height difference is 15m  
Difference between indoor units max. height difference is 0.5m

Twin Systems 8.0kW to 14.3kW

A = main piping, B = branch piping, C = branch piping

A + B + C	Maximum is	50 metres
Difference between B & C	No more than	10 metres
B	Maximum is	20 metres
C	Maximum is	20 metres

Triple Systems 14.3kW

A + B + C + D	Maximum is	50 metres
Difference between B & C or C & D	No more than	10 metres
B	Maximum is	20 metres
C	Maximum is	20 metres
D	Maximum is	20 metres

Twin Systems 22.4 & 28.0 kW – FDC200VS & FDC250VS

Outdoor unit to furthest indoor unit	Maximum is	70 metres
Difference between B & C	no more than	10 metres
B	Maximum is	30 metres
C	Maximum is	30 metres

Triple Systems 22.4 & 28.0 kW – FDC200VS & FDC250VS

Outdoor unit to furthest indoor unit	Maximum is	70 metres
Difference between B & C & D	no more than	10 metres
B	Maximum is	30 metres
C	Maximum is	30 metres
D	Maximum is	30 metres

Quad Systems 22.4 & 28.0 kW – FDC200VS & FDC250VS

Outdoor unit to furthest indoor unit	Maximum is	70 metres
Difference between B & C	no more than	10 metres
Difference between D, E, F, G	no more than	10 metres
B + D	Maximum is	30 metres
B + E	Maximum is	30 metres
C + F	Maximum is	30 metres
C + G	Maximum is	30 metres

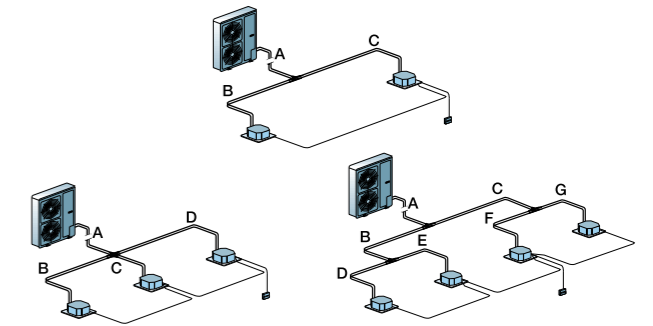

Refrigerant Pipework must be installed within limitations detailed in the table. Each system is supplied with the appropriate branch pipe. Pipe connections to the branch kits must be brazed and it is essential to use nitrogen purge while making the connections.



Refrigerant Pipe Sizes

Outdoor Unit	Clg/Htg kW	System Type	Pipe sizes o.d.(in)			
			A	B	C (& D)	D, E, F, G
FDC71VN	8.0/9.0	TWIN	3/8 5/8	3/8 1/2	3/8 1/2	
FDC100VN	11.2/12.5	TWIN	3/8 5/8	3/8 1/2	3/8 1/2	
FDC125VN	14.0/16.0	TWIN	3/8 5/8	3/8 5/8	3/8 5/8	
FDC140VN	14.8/16.8	TWIN	3/8 5/8	3/8 5/8	3/8 5/8	
FDC140VN	14.8/16.8	TRIPLE	3/8 5/8	3/8 1/2	3/8 1/2	
FDC200VS	22.4/25.0	TWIN	3/8 7/8	3/8 5/8	3/8 5/8	
FDC200VS	22.4/25.0	TRIPLE	3/8 7/8	3/8 5/8	3/8 5/8	
FDC200VS	22.4/25.0	QUAD	3/8 7/8	3/8 5/8	3/8 5/8	3/8 1/2
FDC250VS	28.0/31.5	TWIN	1/2 7/8	3/8 5/8	3/8 5/8	
FDC250VS	28.0/31.5	TRIPLE	1/2 7/8	3/8 5/8	3/8 5/8*	
FDC250VS	28.0/31.5	QUAD	1/2 7/8	3/8 5/8	3/8 5/8	3/8 5/8

\*For 40/50/60 (Indoors) Triple, use 3/8 & 1/2 for the 50 connection

Outdoor Unit Dimensions & Weights

mm	H	W	D	Kg
FDC71VN	750	970	340	60
FDC100VN	845	970	370	74
FDC125VN	845	970	370	74
FDC140VN	845	970	370	74
FDC200VS	1300	970	370	122
FDC250VS	1505	970	370	140