



MITSUBISHI
HEAVY INDUSTRIES, LTD.

AIR CONDITIONING & HEAT PUMP SYSTEMS

8 FD Split Systems **Series** SERVICE GUIDE

Including outdoor unit (FDC 6 Series and 8 Series)

FDT 4-Way Cassette
FDEN Ceiling Suspended
FDKN Wall Mounted
FDR Ducted Cassette
FDU Ducted - High Static



This guide is to assist site service engineers with commissioning of systems and to provide information for maintenance and fault finding.



CONTENTS

Operation

Pages 1 - 15

Wireless Remote Controller

Page 1

Wired Remote Controller

Page 2

Outline of Microcomputer Control Function

Page 3

Operation Control Function by the Wired Remote Controller

Page 11

Operation Control Function by the Outdoor Controller

Page 12

Safety Precautions

Page 16

Maintenance

Pages 17 - 31

Servicing

Page 17

Troubleshooting for Refrigeration Circuit

Page 18

Diagnosing of Microchip Circuit

Page 19



8.4 OUTLINE OF OPERATION CONTROL BY MICROCOMPUTER

(1) Wireless remote controller

Models FDTN (P), FDEN (P), FDKN (P) series

(a) Remote controller

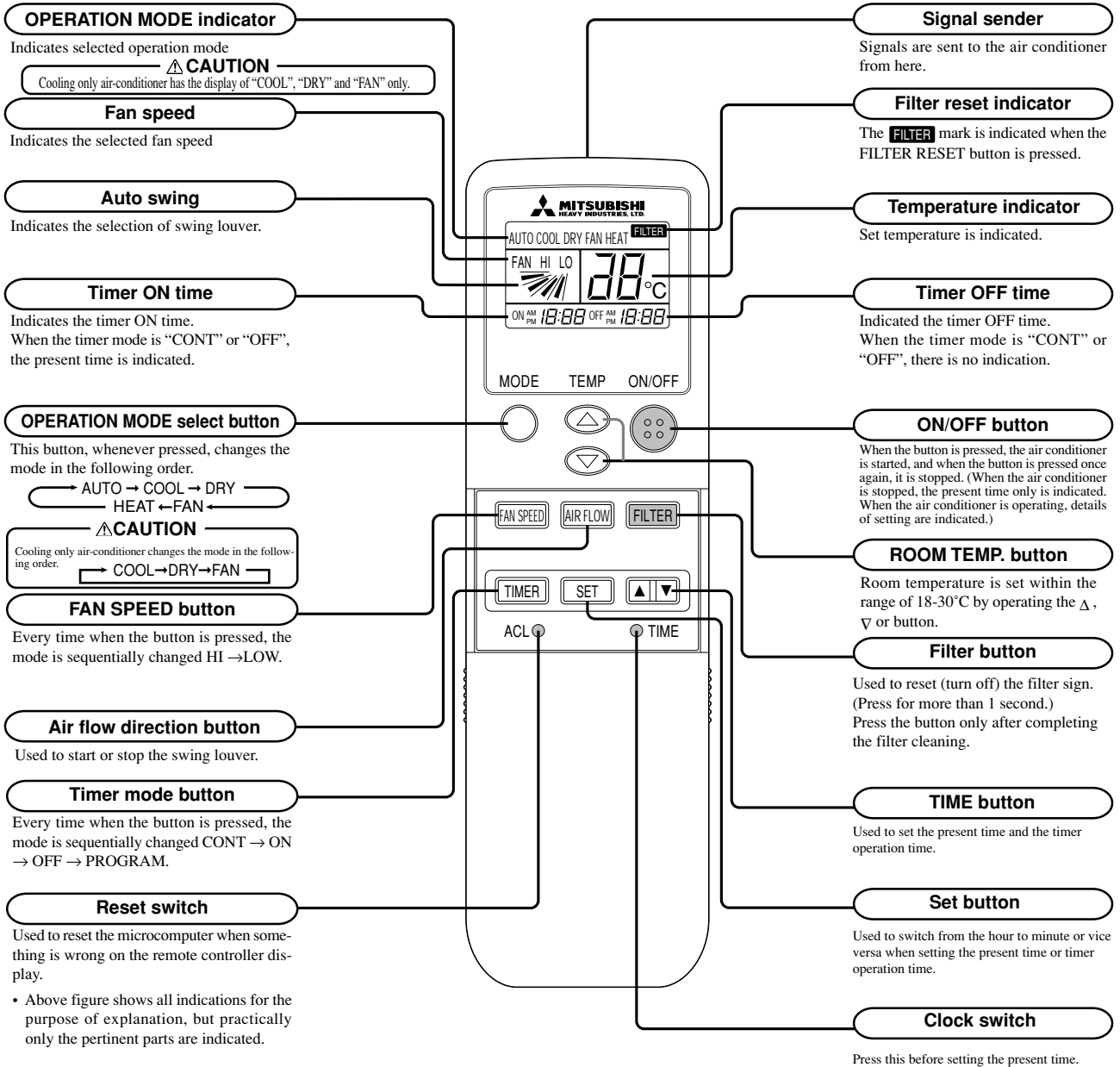

• Above figure shows all indications for the purpose of explanation, but practically only the pertinent parts are indicated.

(b) Indoor unit indicators

Model FDTN(P) series

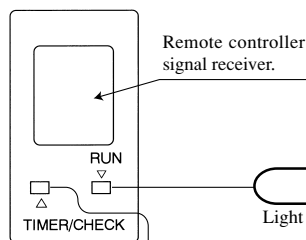

RUN LAMP (GREEN)

Light up : Air conditioner is operating.

TIMER/CHECK (YELLOW)

Light up : Timer mode operating.

Flashing : When some error occurs.

Model FDKN (P) series

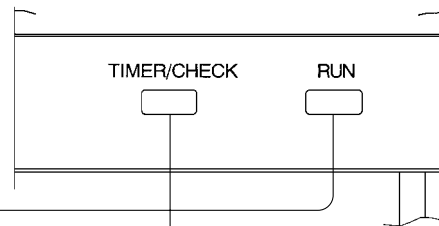

Model FDEN (P) series

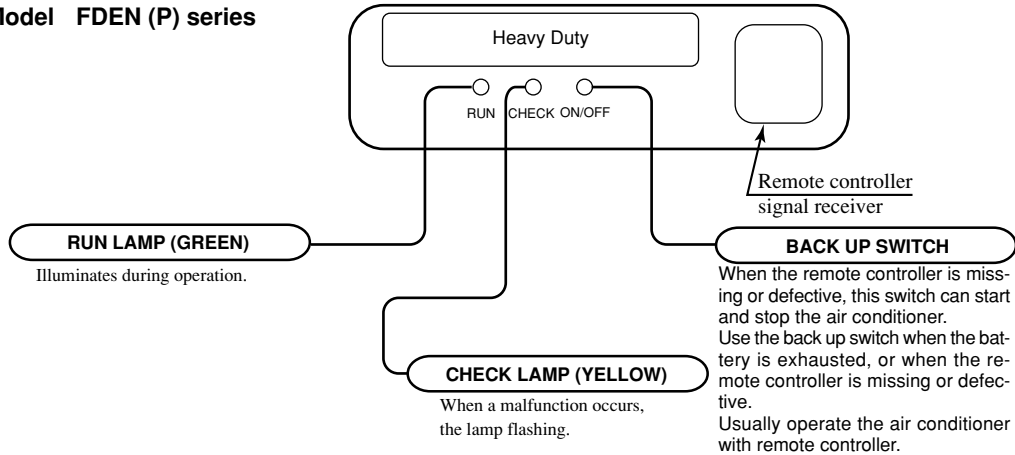

(2) Wired remote controller

Models FDT, FDR, FDU, FDFL series

FDR, FDU and FDFL series are not provided with AUTO SWING switch.

Panel shown below will appear if you open the cover. All contents of display on the LCD are indicated simultaneously for the purpose of explanation.

Pull the knob on the cover to this side to open it downward.

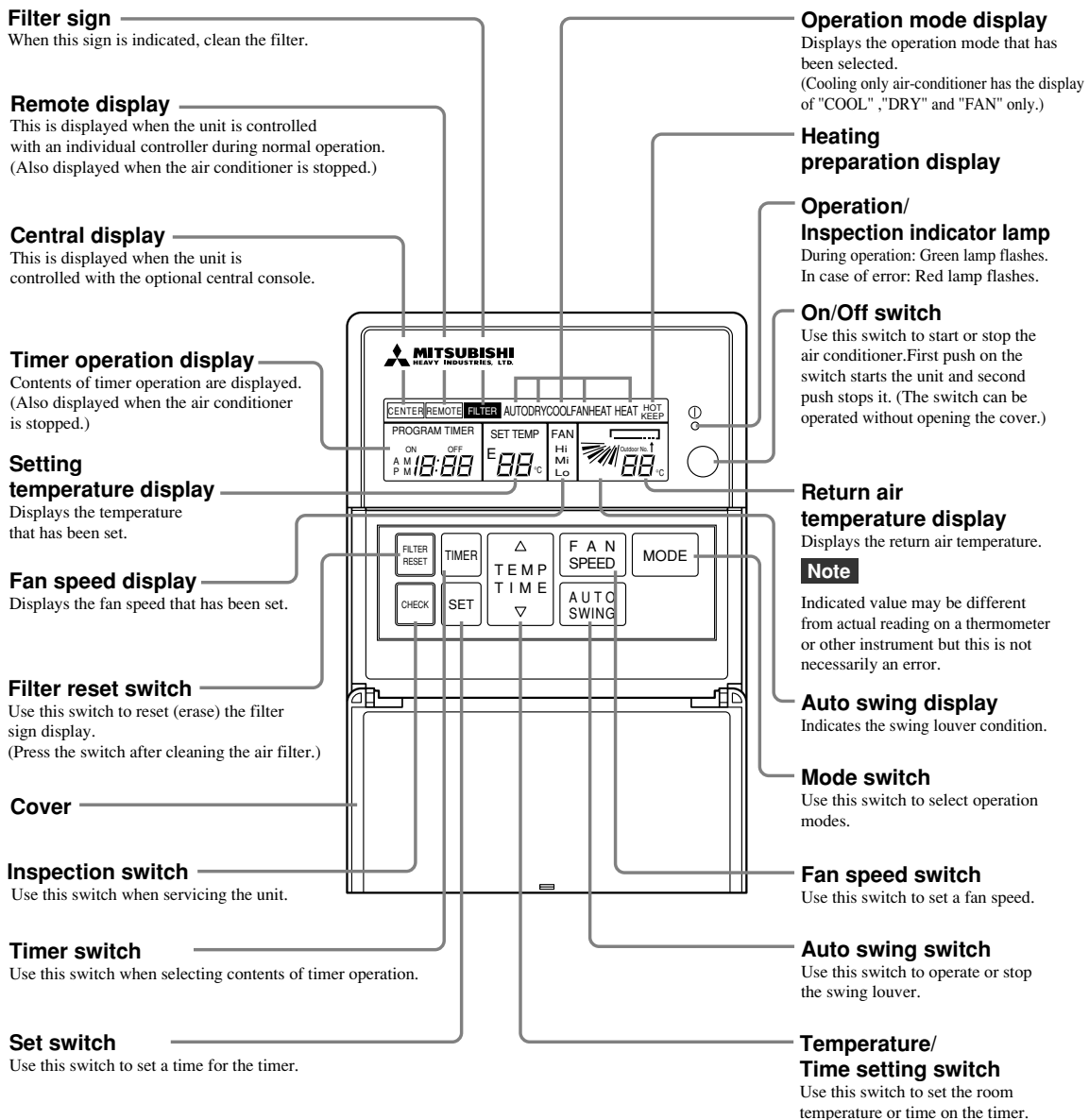

(3) Outline of microcomputer control function

(a) Operation control function by the indoor controller

1) Automatic operation (Only heat pump type)

If the Auto mode is selected on the remote control device, the selection of cooling or heating can be made automatically depending on the room temperature (and the temperature of indoor heat exchanger). (When the switching between the cooling and the heating is made within 3 minutes, the compressor will not operate for 3 minutes.) This will make much easier the switching of cooling/heating at the change of season and can be adapted to the unmanned operation at bank cash dispenser.

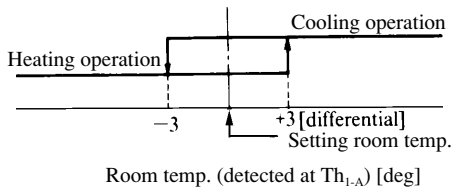

Notes (1) During the automatic switching of cooling/heating the room temperature is controlled based on the setting of room temperature (DIFF:±) 1 deg)

(2) If the temperature of indoor heat exchanger rises beyond 63°C during the heating operation, it is switched automatically to the cooling operation. For an hour after this switching, the heating operation is suspended regardless of the temperature as shown at left.

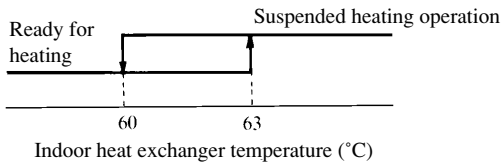

2) Room temperature control (Differential of thermostat)

Heating operation

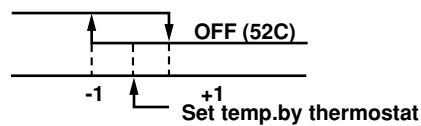

Temperature difference between thermostat set temp. and return air temp. (Detected by ThI-A)

Cooling operation

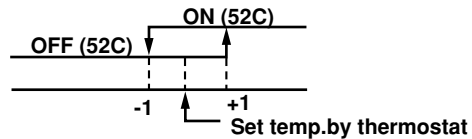

Temperature difference between thermostat set temp. and return air temp. (Detected by ThI-A)

3) Control parts operation during cooling and heating

Function	Cooling		Fan	Heating				Dry	
	Thermostat ON	Thermostat OFF	-	Thermostat ON	Thermostat OFF	Defrost	HOT START	Thermostat ON	Thermostat OFF
Compressor	○	×	×	○	×	○	○	○	×
4-way valve	×	×	×	○	×	×	○	×	×
Outdoor fan	○	×	×	○	×	×	○	○	×
Indoor fan	○		○	○/×				○	
Louver motor	○/×								
Condensate motor	○	×(2min. ON)	×(2min. ON)	×(2min. ON)				○	×(2min. ON)

Note(1) ○ :ON

× :OFF

○/× :According to control other than temperature control.

4) **Dehumidifying operation (“THERMAL DRY”)**

The compressor, the indoor fan motor and the outdoor fan motor are operated intermittently under thermistor (ThI-A) control according to the appropriate operation block, to provide cooling operation for the dehumidifying.

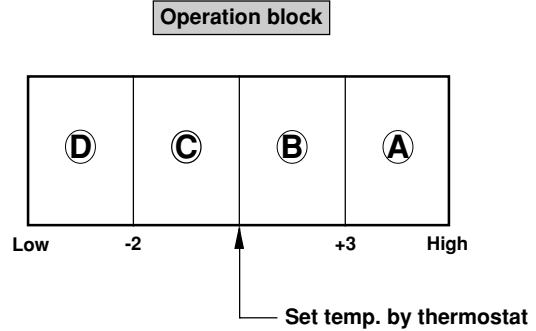

Pattern of operation

CM, FM_o: ON FM_i: ON

Operation block	Thermal drying starting (for 8 or 16 minutes after operation started)	Normal thermal dry operation (after completion of thermal drying)
Ⓐ	(16 minutes)	(8 minutes) Continuous cooling operation (FM:Lo)
Ⓑ	<ul style="list-style-type: none"> Cooling operation (Thermostat ON) Indoor fan operating with the setting air flow. When the thermostat is turned off, the indoor fan operates for 30 seconds with the Lo operation in the wind blowing mode and then stops. 	(8 minutes)
Ⓒ	(8 minutes)	(8 minutes)
Ⓓ		(8 minutes) All stoppage

Notes (1) **Operation block ⒶⒷ** : Normal cooling operation for 16 minutes after operation is started.

Operation stops by thermostat when the set temperature is reached.

After 16 minutes, normal thermal drying operation starts.

Operation block ⒸⒹ : Operation as above is performed for 8 minutes.

After 8 minutes, normal thermal drying operation starts.

(2) **In normal operation, the temperature is checked at 8 minute intervals** after normal thermal drying operation is started, **to determine which operation block is to be selected.**

Operation block Ⓐ thermal drying is carried out if the thermostat set temperature is constant.

5) **Hot spurt (Only heat pump type)**

In the hot spurt mode, the control is conducted at the level +2 higher than the setting temperature at the start of heating operation. The hot spurt is canceled either after the initial thermostat OFF, when the indoor heat exchanger temperature reaches 61°C or 60 minutes after the start of the mode.

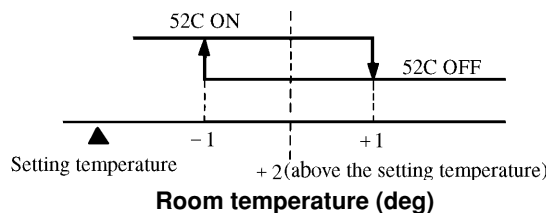

6) FM control with the heating thermostat turned off (For cold draft prevention) (Only heat pump type)

In order to prevent a cold draft while the heating thermostat is turned off, the indoor blower is controlled in response to the temperature of the indoor heat exchanger as illustrated below. It should be noted that if SW3-4 on the indoor PCB is turned off, the indoor blower will stop so far as the temperature of the indoor heat exchanger is lower than 40°C. It will be turned to the Lo operation 5 minutes later.

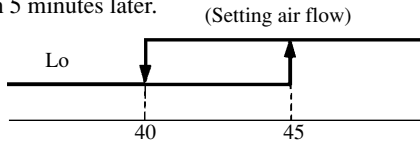

Note (1) After the thermostat is reset, it returns to the hot start control.

7) Hot start (Cold draft prevention during heating) (Only heat pump type)

- 1) If the indoor heat exchanger temperature is lower than 30°C when the heating operation has started, the following indoor blower control is performed.
 - (1) In case of the thermostat off condition: Lo operation
 - (2) In case of the thermostat on condition : Stop
 - (3) If the indoor heat exchanger temperature exceeds 30°C or 7 minutes after the beginning of hot start, the hot start terminates and it returns to the setting airflow of the blower.
- 2) If the indoor heat exchanger temperature is lower than 30°C when the unit is heating under the thermo-ON condition, the indoor fan operates in the Lo mode. As the temperature rises higher than 30 °C or 7 minutes after the beginning of hot start, the hot start terminates and it returns to the setting air flow.

8) Indoor fan control during defrost operation (Only heat pump type)

- 1) The indoor fan operation is changed from the setting airflow to the Lo operation 40 seconds before the start of defrost operation (when the defrost thermostat is turned ON) and stops if the indoor heat exchanger temperature drops below 20°C.
- 2) After the stop as described in 1)-above, the control will be conducted as illustrated below depending on the indoor heat exchanger temperature.

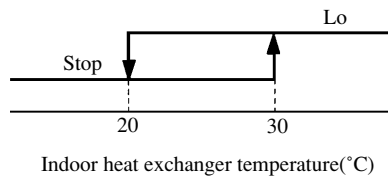

- 3) If the indoor heat exchanger temperature rises beyond 30°C of 7 minutes after the end of defrosting, the indoor fan control related to the defrosting is completed.

9) Condensate pump motor (DM) control (Only FDTN (P), FDT, FDR models)

During the cooling or Dehumidifying operation, the condensate pump motor (DM) is synchronized with the start of compressor operation. If the operation is switched from the operation stop, error stop, thermostat stop and the cooling of defrosting operation to the fan or heating operation, the drain motor continues to operate for 2 minutes after the switching.

Overflow detection by means of the float switch is always on regardless of the operation mode. If an overflow occurs (or the float switch is not connected or the wire is broken), the operation is interrupted as the error stop and the drain motor is operated until the state of float switch is normalized.

10) Defrost control (FDC 6 series only)

Defrost operation is precisely controlled with the defrost thermostat (23DH1, 2) and a timer.

a) Defrost starting conditions

Defrost operation will start only when all of following conditions are met.

- 1) When the compressor operation time accumulated after the start of heating operation exceeds 30 minutes.
- 2) When the compressor operation time accumulated after the end of defrost operation exceeds 45 minutes.
- 3) When the defrost thermostat (23DH1) is turned ON (-6°C)

b) Defrost terminating condition

If the defrost thermostat (23DH2) is turned OFF (12°C) or 12 minutes after the start of defrost operation, the defrost operation is canceled and it returns to the heating operation.

11) 4-way valve control (1 phase models only)

In order to maintain the pressure balance after the stop of compressor during cooling, dehumidifying and heating operation, the 4-way valve is controlled repeatedly as illustrated below.

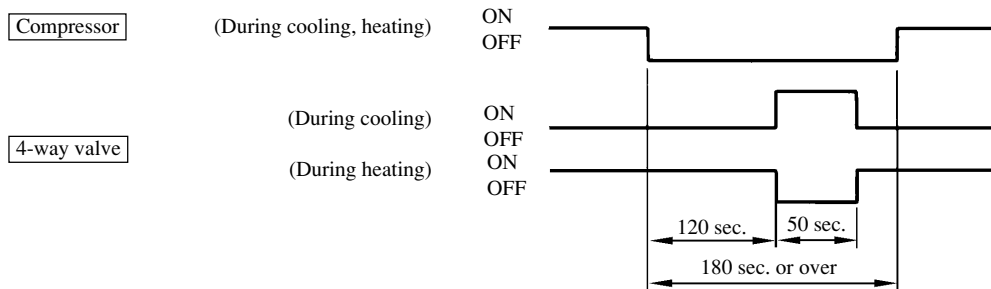

12) Frost prevention during cooling (For indoor heat exchanger)

In order to prevent the frosting during cooling operation, the temperature of indoor unit heat exchanger (detected by Th1-R) is checked 9 min, after the compressor operation start and the unit operation.

This cycle is not operated for 9 min. after the resetting of this frost prevention mechanism.

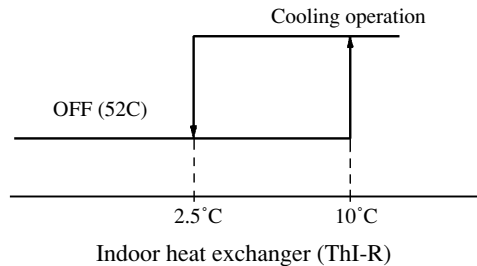

13) Compressor inching prevention control

a) Compressor 3 minutes delay control

The compressor will remain in stop state for three minutes. When the compressor is stopped by thermostat, ON/OFF switch, and/or by occurrence of trouble. When the power source is turned ON, the three-minute delay timer is cancelled.

b) Compressor 3 minutes forced operation control

Compressor cannot be stopped for 3 minutes after it started. However, it will be stopped immediately when the thermostat is turned off due to the operation stop initiated by the ON/OFF switch or the change of operation mode.

Note (1) Both the error control and the protective control take priority over this control.

14) Overload protection during heating

If an overload condition has been detected by the indoor heat exchanger temperature and it has continued for more than 2 seconds during heating, the compressor is stopped. The compressor is started after a delay of 3 minutes and, if the overload condition is detected again within 60 minutes after the initial detection, the compressor is stopped with the error stop.

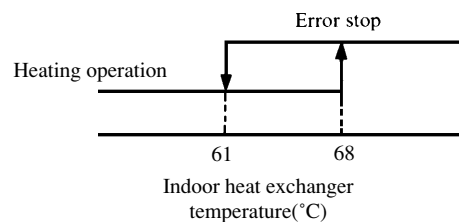

15) Automatic restart control

If there is interruption of power while the unit is operating, the unit operates after power restoration under the same condition as prior to the power interruption. However the compressor will only be able to start three minutes after the power restoration. Furthermore, if the timer was operating prior to the power interruption, the unit remains stopped even after the restoration of service.

Note (1) Becomes invalid if the dip switch SW3-1 on the indoor PC board is at OFF (SW3-1 is set at ON when unit is shipped from the factory).

16) Thermistor disconnection detection control

a) Detection of indoor return air thermistor disconnection

- If there is detection of a disconnection on the return air thermistor in 10 seconds after turning the power ON, the compressor is stopped. If there is a second disconnection on the return air thermistor detected within 60 minutes, there is emergency stop.

Note (1) If the first disconnection on the return air thermistor is detected for a period of 6 continuous minutes, there is emergency stop. If there is no detection of a second disconnection on the return air thermistor within 60 minutes, the first detection becomes invalid.

b) Detection of heat exchanger thermistor disconnection

- If a disconnection is detected on the heat exchanger thermistor in 20 seconds after the compressor has been operating for 2 minutes, the compressor is stopped. If a second disconnection on the heat exchanger thermistor line is detected within 60 minutes, there is emergency stop.

Note (1) If the first disconnection on the heat exchanger thermistor is detected for a period 6 continuous minutes, there is emergency stop.

If there is no detection of second disconnection on the heat exchanger thermistor within 60 minutes, the first detection becomes invalid.

17) Drain detection (Only FDTN(P), FDT, FDR models)

- a) If there is detection of a drain abnormality during cooling operation, the drain pump goes ON for 5 minutes and the compressor which had been running comes to a stop.
- Overflow detection is carried out at all times with the float switch regardless of operational mode. If an overflow is generated (or if the float switch is not yet connected or has been disconnected), there is emergency stop (while the Check lamp (yellow) blinks 4 times) the drain motor operates until reset of the float switch.
- b) If a drain abnormality is detected during cooling operation, there is emergency stop (while the Check lamp (yellow) blinks 4 times) to stop the compressor, and the drain pump is operated with the drain motor until reset of the float switch.
- c) If a drain abnormality is detected during a stop state or fan operation, there is forced operation of the drain pump for 5 minutes. After 5 minutes have elapsed, the drain motor stops if the float switch is reset. Otherwise, there is emergency stop (while the Check lamp (yellow) blinks 4 times) and the drain motor operates until the float switch is reset.
- d) If the float switch is not connected or if there is a disconnection, there is emergency stop.

18) Low voltage guard control

If the power source voltage remains at a value of 80% of rating or less for 3 continuous minutes during operation of the compressor, the compressor stops (52C OFF). Furthermore, if the power source voltage remains at a figure of 15% of rating or greater after 3 minutes have elapsed since stopping the compressor, there is restarting of the compressor (52C ON). Moreover, during stoppage of the compressor, the Run lamp (green) blinks 2 times.

Note (1) When starting the compressor for the first time after turning the operational switch ON, there is starting regardless of the power source voltage. Furthermore, if dip switch SW 3-2 on the internal substrate is OFF, this becomes invalid. (Switch SW 3-2 is set to ON upon shipment from the factory).

19) Refrigerant shortage error

When 52C is ON when operating in cooling (including automatic cooling), if heat exchanger sensor temperature for the indoor unit (Thi -R) does not drop to 25 °C or less for 40 minutes 5 minutes or more after the start of operation, an abnormal stop due to insufficient refrigerant is performed.

20) External control (remote display)/control of input signal

● **External control (remote display) output**

Following output connectors (CNT) are provided on the control circuit board of indoor unit.

- Operation output: Power to engage DC 12V relay (provided by the customer) is outputted during operation.
- Heating output: Power to engage DC 12V relay (provided by the customer) is outputted during the heating operation.
- Compressor ON output: Power to engage DC 12V relay (provided by the customer) is outputted while the compressor is operating.
- Error output: When any error occurs, the power to engage DC 12V relay (provided by the customer) is outputted.

● **Control of input signal**

(Make sure to connect the standard remote control unit. Control of input signal is not available without the standard remote control unit.)

Control of input signal (switch input, timer input) connectors (CNT) are provided on the control circuit board of the indoor unit.

However, when the operation of air conditioner is under the Center Mode, the remote control by CnT is invalid.

- At shipping from factory [FDTN (P), FDEN (P), FDKN (P) models : J3 (SW5-3), FDT, FDR, FDU, FDFL models : J5 (SW5-2)] on PCB OFF]
 - Input signal to CnT OFF → ON [Edge input] ... Air conditioner ON
 - Input signal to CnT ON → OFF [Edge input] ... Air conditioner OFF

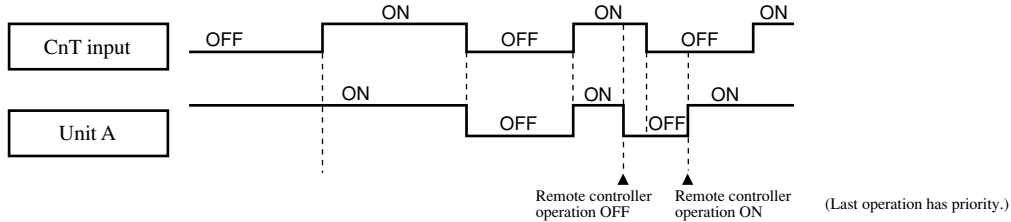

- When J3 (SW5-3) [FDTN (P), FDEN (P), FDKN (P) models] or J5 (SW5-2) [FDT, FDR, FDU, FDFL models] on the PCB of indoor unit is turned on at the field.

Input signal to CnT becomes Valid at OFF Æ ON only and the motion of air conditioner [ON/OFF] is inverted.

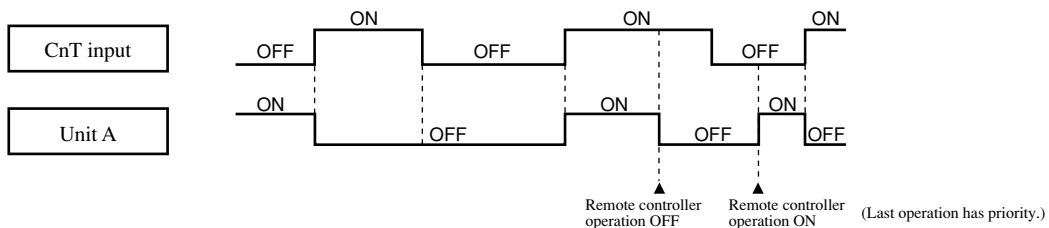

21) **Auto Swing Control** (Excepted FDR, FDU, FDFL models)

- Have a louver motor to move the louvers up and down for the so called “auto swing” function.
- The louver auto swing starts when the AUTO SWING key is pressed once and stops when the AUTO SWING key is pressed again. The louver position is displayed on the LCD on the remote controller. During auto swing, the position displayed on the LCD changes, but the positions of the louvers and the display are not coordinated. (The louvers swing 3 - 4 times per minute but the display changes once per second.)
- **Stopping the louvers**
When the AUTO SWING key is pressed to stop the louver movement, the LCD louver-position display stops and the louvers stop when they come to the position displayed on the LCD. There are four louver stop position on the LCD. (When jumper wire J7 [FDTN (P), FDEN (P) models] or J3 [FDT model] on the indoor unit printed circuit board is cut, the louvers stop immediately at the AUTO SWING key is pressed to stop them and the LCD display changes to show this position. (Excepted FDKN (P) model)
- **Movement of louver when the power supply to the controller controlling 4 positions of the louver is switched on. (Only FDT model)**

When power supply is switched on, the louver will automatically swing about 2 times (without operating remote controller). This is an action for the microcomputer to confirm the louver position in order to input the cycle of the louver motor (LM) to the microcomputer with the limit switch (LS) pushing the louver motor (LM). If the LS action is not input to the microcomputer, the louver will stop within 1 minute after the power supply is switched on and will not move from then on.

- **Keeping the louvers horizontal during heating (Only heat pump type)**

While HOT KEEP is displayed (during hot start operation or when the thermostat has turned off during heating operation), the louvers stay in the horizontal position to prevent cold drafts, independent of the setting of the AUTO SWING key (auto swing or stop). The louver position display of LCD displays continuously the original position before this control operation.

When the HOT KEEP display goes out, both the louvers and the LCD display return to their previous position.

(However, after the power supply to the unit is switched on, the louvers swing two times as a check of the power source frequency, regardless of the settings of the ON / OFF or AUTO SWING keys).

22) Using 1 remote controller to control multiple units (indoor units - up to 16 units) (Only FDT, FDR, FDU, FDFL models)

a) Function

A single remote control switch can be used for group control of multiple units (indoor units - up to 16 units). All units in the group that have had the remote control switch set at [Operating Mode] can be turned on and off in order of the unit number. This functions independently of the thermostat and protection functions of each unit.

Notes (1) The unit number is set by a switch (SW1) on the circuit board for the indoor unit.

Set SW1 : 0~F

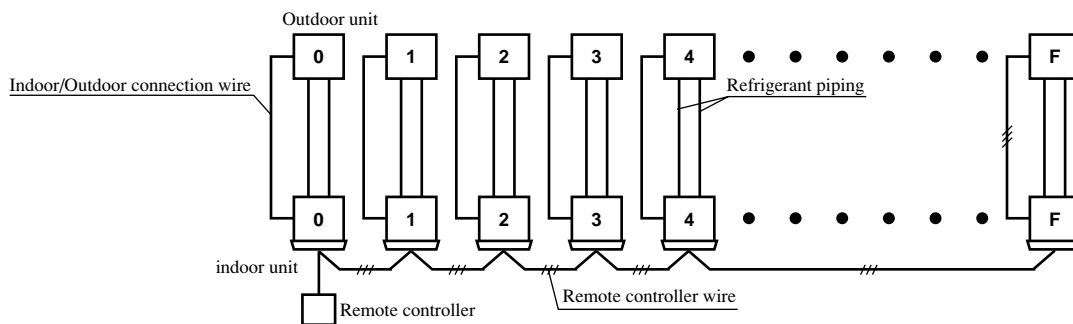

(2) If unit number is not important, random can be used. However, setting in order from 0, 1, 2, to F will ensure setting without error.

b) Display to remote controller

(i) **Return air temperature, by remote or center and heating preparation:** Displays for the youngest unit for the remote mode (center mode if there is no remote mode) of the units in operation.

(ii) **Inspection and filter sign:** Displays either to the first corresponding unit.

c) Confirmation of connected units

Each push of the inspection switch on the remote control displays the units connected in sequential order from the youngest unit.

d) Error

(i) If an error occurs (protection device activation) with some of the units in the group, those units will have an error stop, but the properly operating units will continue operation.

(ii) Wiring outline

Route the wire connecting each of the indoor and outdoor units as it would be for each unit. Use the terminal block (X, Y, Z) for the remote control for the group controller and use a jumper wire among each of the rooms.

(b) Operation control function by the wired remote controller

(i) The following is the sequence of operation for the remote controller operation mode switch.

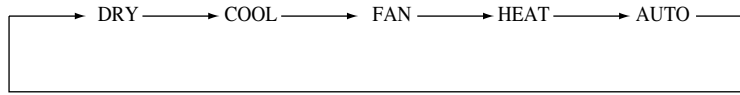

(ii) CPU reset

This functions when the " inspection " and " filter reset switch " on the remote controller are pushed simultaneously. It operates in the same manner as the power reset.

(iii) Power outage compensation function.

- This is enabled by setting dip switch SW3 on the remote control circuit board to ON.
- It records the normally used remote control modes. Once power has been restored, it restarts operation by using the contents of the memory. Note that the stop positions for auto swing and the timer mode are cancelled.

Parts layout on the remote controller PCB

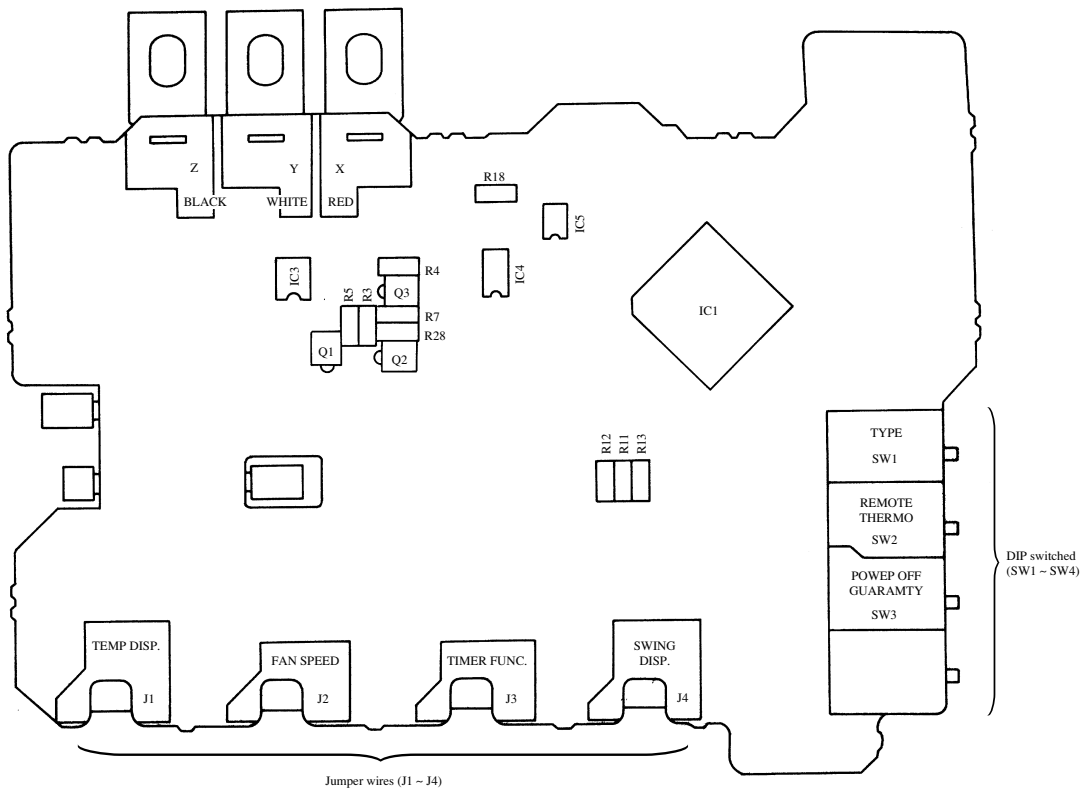

• Function of DIP switched

Switch		Function
SW1	ON	Cooling only type
	OFF	Heat pump type
SW2	ON	Remote control sensor - Enabled
	OFF	Remote control sensor - Disabled
SW3	ON	Power outage compensation - ON
	OFF	Power outage compensation - OFF

• Function of Jumper wires

Switch		Function
J1	Wich	Inlet temperature display - Enabled
	None ⁽¹⁾	Inlet temperature display - Disabled
J2	Wich	Fan display - 3 speeds
	None ⁽¹⁾	Fan display - 2 speeds
J3	Wich	Timer function - Enabled (Normal)
	None ⁽¹⁾	Timer function - Disabled
J4	Wich	Auto swing display - ON
	None ⁽¹⁾	Auto swing display - OFF

Note (1) 'None' means that jumper wire is not provided on the PCB or the connection ic cut.

(c) Operation control function by the outdoor controller (Only FDC(P)208~508 type, FDC808, 1008 type)

1) **Control for outdoor unit fan**

a) **Cooling Operation**

The speed of the fan for the outdoor unit is controlled by the temperature of the heat exchanger (Tho-R detection) and the outdoor air temperature (Tho-A).

Models FDC(P)208~508 type

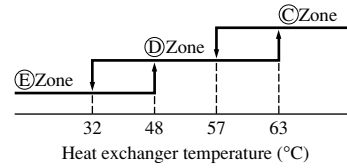
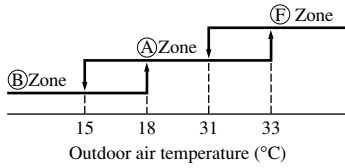

Description of control for fan for outdoor unit

Model		FDC(P)208~308 type		FDC(P)408, 508 type	
Fan motor		FM ₀		FM ₀₁ (Up)	FM ₀₂ (Lo)
Zone	A Zone	C Zone	Hi	Hi	Hi
		D Zone	Hi	Hi	OFF
		E Zone	Hi	Hi	OFF
	B Zone	C Zone	Hi	Hi	Hi
		D Zone	Hi	Hi	OFF
		E Zone	Lo	Lo	OFF
E Zone		Hi	Hi	Hi	

Models FDC808, 1008 type

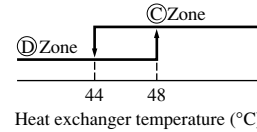
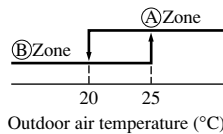

Description of control for fan for outdoor unit

Fan motor		FM ₀₁ (Left)	FM ₀₂ (Right)
Zone	A Zone	Hi	Hi
	B Zone	C Zone	OFF
		D Zone	Lo
			OFF

b) **Heating Operation**

① Stop control for outdoor fan

When the high pressure switch (63H₂) operates, the fan for the outdoor unit is stopped to control the high pressure switch.

63H₂ settings

Models FDC208~1008 type

2.5 OFF/2.06 ON (MPa)
[25.5 OFF/21 ON (kgf/cm²)]

Models FDCP208~508 type

2.79 OFF/2.26 ON (MPa)
[28.5 OFF/23 ON (kgf/cm²)]

② Tap control for outdoor fan

When the high pressure switch (63H₂) is closed, the outdoor fan is controlled by the detected heat of the outdoor heat exchanger thermistor (Tho-R) and the detected heat of the outdoor air temperature thermistor (Tho-A).

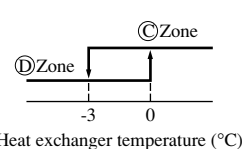
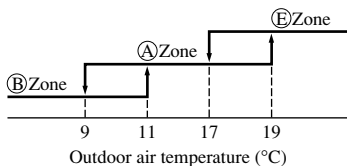

Description of control for fan for outdoor unit

Model		FDC(P)208~308 type		FDC(P)408, 508 type		FDC808, 1008 type	
Fan motor		FM ₀		FM ₀₁ (Up)	FM ₀₂ (Lo)	FM ₀₁ (Left)	FM ₀₂ (Right)
Zone	A Zone	C Zone	Hi	Hi	OFF	Hi	OFF
		D Zone	Hi	Hi	Hi	Hi	
	B Zone		Hi	Hi	Hi	Hi	Hi
		C Zone	Lo	Lo	OFF	Hi	OFF
	E Zone		Hi	Hi	OFF	Hi	Hi
		D Zone					

Note (1) When the fan for the outdoor unit is started when the outdoor air temperature is more than 12 °C, it will operate at high speed for 3 seconds and then switch to low speed. After operating a low speed for 4 minutes, it will be transferred to controlled speed.

2) **Control of fan for outdoor unit for de-icing**

If DIP switch SW5-2 on the printed circuit board for the outdoor unit is set to on, the fan on the outdoor unit which has been stopped will operate for 10 seconds at Hi speed every 10 minutes when the outdoor air temperature is 3 °C or less.

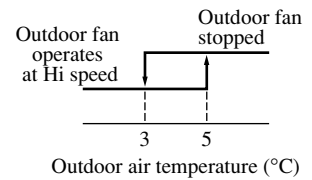

3) **Discharge temperature control during cooling/heating (Only case of FDC(P)208~508 type)**

As the discharge gas temperature (detected with Tho-D) rises during cooling/heating operation, the capillary bypass and the liquid bypass solenoid valve (SV1) are opened so that the abnormal rise of discharge gas temperature is prevented.

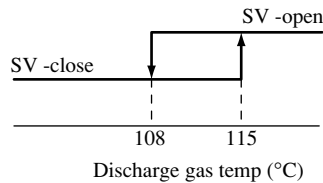

4) **Defrost control**

Defrost operation will start when the temperature of the heat exchanger for the outdoor unit (Tho-R detection) and the outdoor air temperature (Tho-A detection) enter the start of defrost range shown in the figure below.

Initiation temp. of defrosting (Detected by Tho-R, Tho-A)

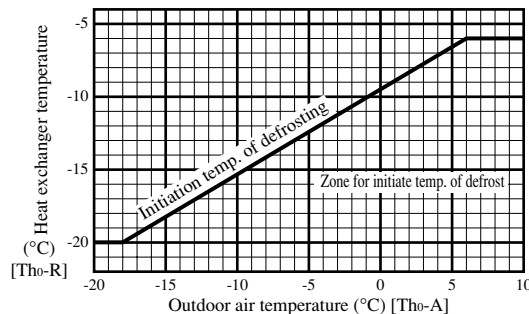

Note (1) If DIP switch SW5-1 on the printed circuit board for the outdoor unit is set to on, defrost operation will begin when temperature of the heat exchanger for the outdoor unit reaches -7 °C.

a) **Defrost Operation**

Switching of the control of the 4-way selector valve during defrost operation can be performed by enabling/disabling the jumper wire (J17) on the printed circuit board for the outdoor unit.

- (i) J17 None (4-way selector valve ON during heater operation)

Defrost operation is performed with the compressor on, the fan for the outdoor unit off and the 4-way selector valve off.

- (ii) J17 With (4-way selector valve OFF during heater operation)

Defrost operation is performed with the compressor on, the fan for the outdoor unit off and the 4-way selector valve on.

b) **Defrost finished**

- (i) Once defrost operation has started, it will finish after the cumulative operating time of the compressor has reached 12 minutes (factory setting: SW5-1 OFF).

Note (1) This time will become 14 minutes if the DIP switch (SW5-1) on the printed circuit board on the outdoor unit is set to on.

- (ii) Switching of the defrost recovery time can be performed by enabling/disabling the jumper wire (J18) on the printed circuit board for the outdoor unit.

J18 (SW6-2) With: 14 °C, J18 (SW6-2) None: 18 °C

5) **Compressor protecting function (Microcomputer and phase protection relay)**

a) Overcurrent control

- (i) When a 52C secondary L₁-phase continues for 0.5 seconds and when it is more than the set value (detection at current sensor CT), the compressor is stopped. The compressor is restarted after a 3-minute delay if the detection current is less than 1.5 to 2A. If this condition is re-detected 5 times within 60 minutes of the first occurrence, an abnormal stop of the unit is performed.
- (ii) If 60 minutes passes and the detected current after the first to the fourth stoppage is not less than 1.5~2A, an abnormal stop of the unit is performed.

b) Open-phase protection

When a 52C secondary detection current continues for 4 seconds when the compressor is on and when it is less than 1.5 to 2 A, it is determined to be a open-phase of the 52C secondary N-phase, and the compressor is stopped. The compressor is restarted after a 3-minute delay and if this condition is re-detected within 60 minutes of the first occurrence, an abnormal stop of the unit is performed.

c) Detection of abnormal discharge temperature (Only case of FDC(P)208~508 type)

- (i) When an abnormally high temperature is detected at the discharge pipe of the compressor (Tho-D detection), the compressor is stopped. The compressor is restarted after a 3-minute delay and if this condition is re-detected 5 times within 60 minutes of the first occurrence, an abnormal stop of the unit is performed.

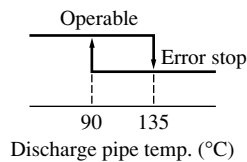

- (ii) If 60 minutes passes and the detected temperature after the first to the fourth stoppage is not less than 90 °C, an abnormal stop of the unit is performed.

Note (1) Once an abnormal discharge temperature has occurred, restarting cannot be performed for 45 minutes. [Detection temperature less than 3 °C]. (In failure mode, resetting cannot be performed by remote control.)
Operation is possible after 45 minutes. (Cleared by resetting power source.)

d) Cooling overload protection

State of overload during cooling operation is detected (with Tho-R) based on the temperature of outdoor heat exchanger and the unit operation is stopped / Immediate reset after repair

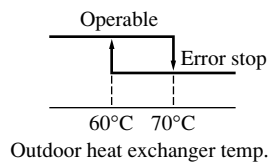

e) Thermistor [Discharge piping (Only case of FDC(P)208~508 type), Heat exchanger and outdoor air thermistor] disconnected wire

- (i) If there is a disconnected wire or if there is a big difference in performance characteristics, an abnormal stop of the unit is performed. ⇨ Restore after repairing.

6) **High-pressure protection by high-pressure make-or-break device (63H₁)**

(Only case of FDCP208-508 and FDC808, 1008 type)

- a) If the pressure rises and 63H₁ is operated (opened), the compressor is stopped. After a 3-minute delay, the compressor is restarted. An abnormal stop is performed when 63H₁ is opened five times within 60 minutes of the first operation. ⇨ Restore after repairing.
- b) An abnormal stop is performed at the first occurrence if 63H₁ remains open after 60 minutes have passed from the first time the compressor was stopped.

Note (1) Once 63H₁ has been restored after an abnormal stop, the unit can be restarted using the remote control.

7) **Compressor motor protection (Only case of FDC808, 1008 type)**

The same detection control as 63H₁ will be performed when the internal thermostat 49C operates due to a rise in the windings of the compressor motor. The setting values of the internal thermostat 49C are 90 °C open and 73 °C close.

8) **Control of the closing and opening of the service valve (Only heat pump type)**

- a) When the compressor is ON for the first time after turning on the power, the heating operation starts regardless of any setting.
- b) If the 63H₂ turns OFF(open) within 10 seconds after the compressor is ON, the power will turn off as abnormal stop.
- c) To recover from the abnormal stop, turn on the power again after the 63H₂ is ON(closed).
- d) If the 63H₂ doesn't turn OFF(open) within 10 seconds after the compressor is ON, the operation immediately changes to the "set mode" to start normal operation.

9) **Test run**

- a) For a test run, it is possible to use the dip switches SW5-3 and SW5-4 on the printed circuit board in the outdoor unit.

SW5-3	ON	SW5-4	OFF	Test run for cooling
			ON	Test run for heating
	OFF	Normal		

- b) Test run time is 30 minutes. Protective devices are effectively controlled.

8.5 APPLICATION DATA

SAFETY PRECAUTIONS

- Please read these “Safety Precautions” first then accurately execute the installation work.
- Though the precautionary points indicated herein are divided under two headings, **⚠WARNING** and **⚠CAUTION**, those points which are related to the strong possibility of an installation done in error resulting in death or serious injury are listed in the **⚠WARNING** section. However, there is also a possibility of serious consequences in relationship to the points listed in the **⚠CAUTION** section as well.

In either case, important safety related information is indicated, so by all means, properly observe all that is mentioned.

- After completing the installation, along with confirming that no abnormalities were seen from the operation tests, please explain operating methods as well as maintenance methods to the user (customer) of this equipment, based on the owner’s manual.

Moreover, ask the customer to keep this sheet together with the owner’s manual.

⚠WARNING

- This system should be applied to places of office, restaurant, residence and the like. Application to inferior environment such as engineering shop could cause equipment malfunction.
- Please entrust installation to either the company which sold you the equipment or to a professional contractor. Defects from improper installations can be the cause of water leakage, electric shocks and fires.
- Execute the installation accurately, based on following the installation manual. Again, improper installations can result in water leakage, electric shocks and fires.
- When a large air-conditioning system is installed to a small room, it is necessary to have a prior planned countermeasure for the rare case of a refrigerant leakage, to prevent the exceeding of threshold concentration. In regards to preparing this countermeasure, consult with the company from which you purchased the equipment, and make the installation accordingly. In the rare event that a refrigerant leakage and exceeding of threshold concentration does occur, there is the danger of a resultant oxygen deficiency accident.
- For installation, confirm that the installation site can sufficiently support heavy weight. When strength is insufficient, injury can result from a falling of the unit.
- Execute the prescribed installation construction to prepare for earthquakes and the strong winds of typhoons and hurricanes, etc. Improper installations can result in accidents due to a violent falling over of the unit.
- For electrical work, please see that a licensed electrician executes the work while following the safety standards related to electrical equipment, and local regulations as well as the installation instructions, and that only exclusive use circuits are used.
Insufficient power source circuit capacity and defective installment execution can be the cause of electric shocks and fires.
- Accurately connect wiring using the proper cable, and insure that the external force of the cable is not conducted to the terminal connection part, through properly securing it. Improper connection or securing can result in heat generation or fire.
- Take care that wiring does not rise upward, and accurately install the lid/service panel. Its improper installation can also result in heat generation or fire.
- When setting up or moving the location of the air-conditioner, do not mix air etc. or anything other than the designated refrigerant (R22) within the refrigeration cycle.
Rupture and injury caused by abnormal high pressure can result from such mixing.
- Always use accessory parts and authorized parts for installation construction. Using parts not authorized by this company can result in water leakage, electric shock, fire and refrigerant leakage.

⚠CAUTION

- Execute proper grounding. Do not connect the ground wire to a gas pipe, water pipe, lightning rod or a telephone ground wire. Improper placement of ground wires can result in electric shock.
- The installation of an earth leakage breaker is necessary depending on the established location of the unit. Not installing an earth leakage breaker may result in electric shock.
- Do not install the unit where there is a concern about leakage of combustible gas.
The rare event of leaked gas collecting around the unit could result in an outbreak of fire.
- For the drain pipe, follow the installation manual to insure that it allows proper drainage and thermally insulate it to prevent condensation. Inadequate plumbing can result in water leakage and water damage to interior items.

8.6 MAINTENANCE DATA

8.6.1 Servicing

(1) Evacuation

The evacuation is a procedure to purge impurities, such as noncondensable gas, air, moisture from the refrigerant equipment by using a vacuum pump. Since the refrigerant R22 and R407C is very insoluble in water, even a small amount of moisture left in the refrigerant equipment will freeze, causing what is called ice clogging.

Evacuation procedure

Make sure that the both service valves of gas and liquid line are fully opened.

- (a) Check to ensure that there is no internal pressure in the unit. If there is an internal pressure, it should be relieved through the service port.
 - (b) Connect the charging hose of the gauge manifold to the service port of the gas piping. Close high pressure valve ② of gauge manifold.
 - (c) Connect the charging hose ① to a vacuum pump.
- Repeat evacuation in the following sequence.

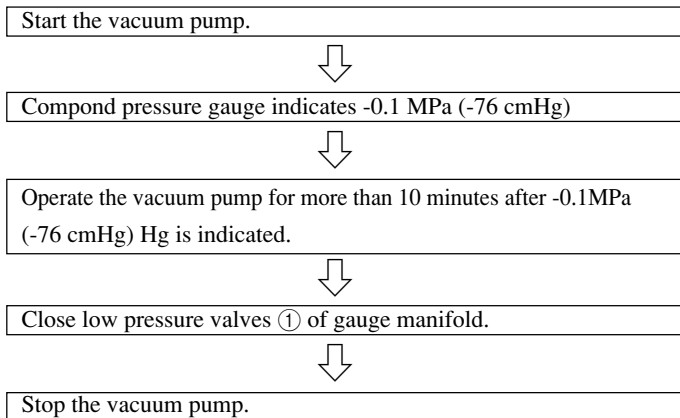

- Notes (1) Do not use the refrigerant pressure to expel air.
(2) Do not use the compressor for evacuation.
(3) Do not operate the compressor in a vacuum condition.

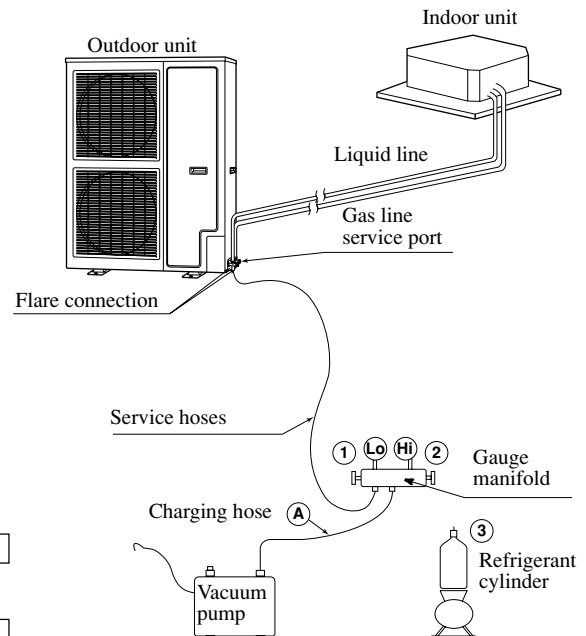

- Notes (1) Refer to the exterior-view drawing for the position of the service valve.
(2) When connecting of the service valve, flare connection for both the indoor and outdoor unit.

(2) Refrigerant charging

(a) After the evacuation shown in the above, change the connection of the charge hose (A) to the refrigerant cylinder.

(b) Purge air from the charge hose (A) .

First loosen the connecting portion of the charge hose at the gauge manifold side and open valve (3) for a few seconds, and then immediately retighten it after observing that gas has blown out from loosened connecting portion.

(c) Open valves (1) and (3) then gas refrigerant begins flowing from the cylinder into the unit.

When refrigerant has been charged into the unit to some extent, refrigerant flow becomes stagnant. When that happens, start the compressor in cooling cycle until the system is filled with the specified amount of gas, then close valves (1) and (3) and remove the gauge manifold. Cover the service port with caps and tighten them securely.

(d) Check for gas leakage by applying a gas leak detector around the piping connection.

(e) Start the air conditioner and make sure of its operating condition.

8.6.2 Trouble shooting for refrigerant circuit

(1) Judgement of operating condition by operation pressure and temperature difference

Making an accurate judgement requires a skill that is acquired only after years of experience, one trouble may lead to another trouble from a single trouble source and several other troubles may exist at the same time which comes from an undetected different trouble source.

Filtering out the trouble sources can be done easier by comparing with daily operating conditions. Some good guides are to judge the operating pressure and the temperature difference between suction air and delivery air.

Following are some pointers,

Circuit	Pressure						Trouble cause
	Indication	Too low	A little low	Normal	A little high	Too high	
High side Low side						●	1) Excessive overcharging of refrigerant 2) Mixture of non condensable gas (air etc.)
High side Low side	●					●	Ineffective compression (defective compressor)
High side Low side	●		●				1) Insufficient refrigerant in circuit 2) Clogging of strainer 3) Gas leakage 4) Clogging of air filter (in cooling) 5) Decrease in heat load (in cooling) 6) Locking of indoor fan (in cooling)
High side Low side					●	●	1) Locking of outdoor unit fan (in cooling) 2) Dirty outdoor heat exchanger (in cooling) 3) Mixture of non condensable gas (air etc.)
High side Low side					●	●	1) Too high temperature of room

8.6.3 Diagnosing of microcomputer circuit

(1) Selfdiagnosis function

(a) Indoor unit side

(i) Only case of wireless remote control model.

Check indicator table

Failure mode on the indoor unit indicated by flashing Yellow LED and Green LED.

Indoor unit LED		Failure at:	Contents of the failure
Yellow	Green		
1 time flash	–	Indoor unit heat exchanger thermistor Indoor unit circuit board	<ul style="list-style-type: none"> Indoor unit heat exchanger thermistor defective (element defective or broken wire). Defective connection of connector for thermistor. Indoor unit circuit board defective (defective thermistor input circuit)?
2 time flashes	–	Indoor unit air return thermistor Indoor unit circuit board	<ul style="list-style-type: none"> Indoor unit return thermistor defective (element defective or broken wire). Defective connection of connector for thermistor. Indoor unit circuit board defective (defective thermistor input circuit)?
4 time flashes	–	Failure in drainage Float switch Indoor circuit board	<ul style="list-style-type: none"> Failure with the condensate pump (DM), or open circuit or disconnection of connector with the condensate pump. Malfunctioing of the float switch (erroneous functioning) Indoor unit circuit board defective (defective float switch input circuit) Indoor unit circuit board defective (defective DM driving output circuit)
5 time flashes	–	Insufficient refrigerant Indoor unit heat exchanger thermistor Indoor unit circuit board	<ul style="list-style-type: none"> Gas leak. Indoor unit heat exchanger thermistor defective (short circuit). Indoor unit circuit board defective (defective thermistor input circuit)?
6 time flashes	–	Installation and operating conditions Indoor unit heat exchanger thermistor Indoor unit circuit board	<ul style="list-style-type: none"> Heating overload (temperature of heat exchanger for indoor unit abnormally high) Indoor unit heat exchanger thermistor defective (short circuit)? Indoor unit circuit board defective (defective thermistor input circuit)?
–	2 time flashes	Low voltage protection	<ul style="list-style-type: none"> When the power source voltage is 80% of rating or lower.

Note (1) Inspection LED display has a cycle of 8 seconds (flashing time of 0.5 seconds).

(ii) Only case of wired remote control model.

Table of inspection items based on error codes

Error Code	Failure at:	Contents of the failure
E1	Operating switch wire (signal noise)	<ul style="list-style-type: none"> Defective connection or broken wire for operating switch signal wire. Signal noise has entered the operating switch wire.
	Circuit board for operating switch or indoor unit	<ul style="list-style-type: none"> Is the circuit board for the operating switch or the circuit board for the indoor unit is defective (communication circuit defective)?
E6	Indoor unit heat exchanger thermistor	<ul style="list-style-type: none"> Indoor unit heat exchanger thermistor defective (element defective or broken wire). Defective connection of connector for thermistor.
	Indoor unit circuit board	<ul style="list-style-type: none"> Indoor unit circuit board defective (defective thermistor input circuit)?
E7	Indoor unit air inlet thermistor	<ul style="list-style-type: none"> Indoor unit return thermistor defective (element defective or broken wire). Defective connection of connector for thermistor.
	Indoor unit circuit board	<ul style="list-style-type: none"> Indoor unit circuit board defective (defective thermistor input circuit)?
E8	Installation and operating conditions	<ul style="list-style-type: none"> Heating overload (temperature of heat exchanger for indoor unit abnormally high)
	Indoor unit heat exchanger thermistor	<ul style="list-style-type: none"> Indoor unit heat exchanger thermistor defective (short circuit).
	Indoor unit circuit board	<ul style="list-style-type: none"> Indoor unit circuit board defective (defective thermistor input circuit)?
E9	Failure in drainage	<ul style="list-style-type: none"> Failure with the condensate pump (DM), or open circuit or disconnection of connector with the condensate pump.
	Float switch	<ul style="list-style-type: none"> Malfunctioing of the float switch (erroneous functioning)
	Indoor circuit board	<ul style="list-style-type: none"> Indoor unit circuit board defective (defective float switch input circuit) Indoor unit circuit board defective (defective DM driving output circuit)
E10	Number of indoor units connected	<ul style="list-style-type: none"> 1 Remote controller for multiple unit control, 17 or more indoor units connected
E57	Insufficient refrigerant	<ul style="list-style-type: none"> Gas leak.
	Indoor unit heat exchanger thermistor	<ul style="list-style-type: none"> Indoor unit heat exchanger thermistor defective (short circuit).
	Indoor unit circuit board	<ul style="list-style-type: none"> Indoor unit circuit board defective (defective thermistor input circuit)?

(3) Error diagnosis procedures at the indoor unit side

To diagnose the error, measure the voltage (AC, DC), resistance, etc. at each connector around the circuit board of indoor unit based on the inspection display or the operation state of unit (no operation of compressor or blower, no switching of 4-way valve, etc.). If any defective parts are discovered, replace with the assembly of parts as shown below.

(a) Single-unit replacement parts for circuit board of indoor unit. (Peripheral electric parts for circuit board.)

Indoor unit printed circuit board, thermistor (return, heat exchanger), operating switches, limit switches, transformers, fuses.

Note (1) Use normal inspection methods to determine the condition of strong electrical circuits and frozen cycle parts.

(b) Replacement procedure of indoor unit microcomputer printed circuit board

Microcomputer printed circuit board can be replaced with following procedure.

- (i) Confirm the parts numbers. (Refer to the following parts layout drawing for the location of parts number.)

Model	Parts number	Model	Parts number
FDTN(P), FDEN(P)	PJA505A069	FDKN(P)258, 308	PHA505A008
FDKN(P)208	PHA505A007	FDT, FDR, FDU, FDFL	PJA505A092Z

Parts layout on the indoor unit PCB

Models: FDTN (P), FDEN (P) series

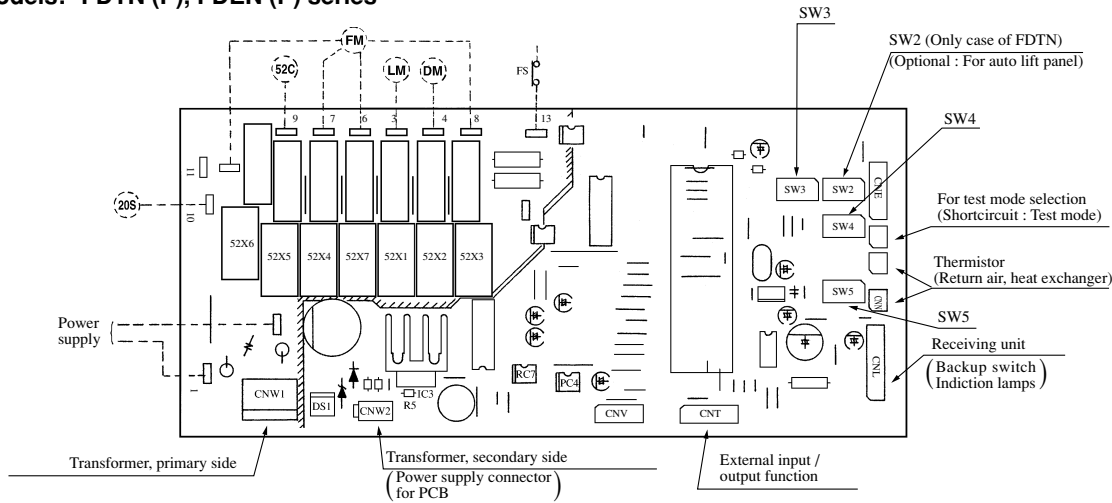

Model: FDKN (P) series

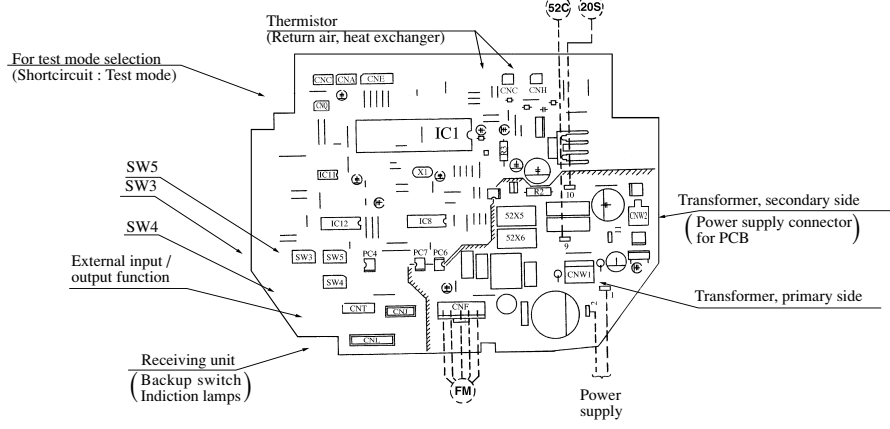

• Function of jumper wires

Name	Function	
J1(SW5-1)	With	1 Phase model
	None	3 Phase model
J2(SW5-2)	With	Cooling only type
	None	Heat pump type
J3(SW5-3)	With	Pulse input
	None	Step input
J4(SW4-1)	With	—
	None	—
J5(SW4-2)	With	Antifrost 2.5°C
	None	Antifrost 1°C
J6(SW4-3)	With	With abnormality resetting
	None	Without abnormality resetting
J7(SW4-4)	With	4 position louver control: valid
	None	4 position louver control: invalid
*1 J7(SW4-4)	With	FDKN208 type
	None	FDKN258, 308 type

Note (1) *1 J7 (SW4-4) is for switching models on the FDKN (P) Series.

• Function of DIP switched (SW3)

Switch	Function	
SW3-1	ON	Power off guaranteed
	OFF	No power off guaranteed
SW3-2	ON	With low-voltage detection control
	OFF	Without low-voltage detection control
SW3-3	ON	Power up mode (UHi-Lo)
	OFF	Mild mode (Hi-Lo)
SW3-4	ON	Indoor fan is Lo when heating thermostat is OFF.
	OFF	Indoor fan is OFF when heating thermostat is OFF.

Model: FDT, FDR, FDU, FDFL series

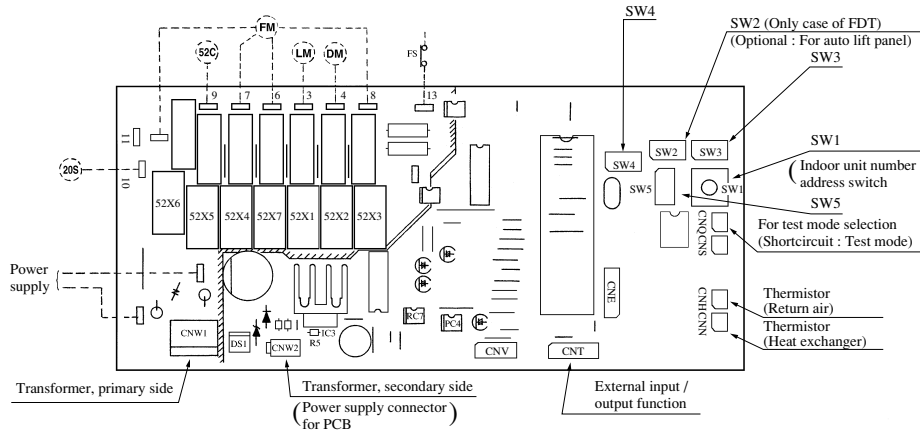

• Function of DIP switched (SW3)

Switch	Function	
SW3-1	ON	Power off guaranteed
	OFF	No power off guaranteed
SW3-2	ON	With low-voltage detection control
	OFF	Without low-voltage detection control
SW3-3	ON	Power up mode (UHi-Lo)
	OFF	Mild mode (Hi-Lo)
SW3-4	ON	Indoor fan is Lo when heating thermostat is OFF.
	OFF	Indoor fan is OFF when heating thermostat is OFF.

• Function of DIP switched (SW4, 5)

Switch	Function	
SW4-1(J1)	ON	Antifrost 2.5°C
	OFF	Antifrost 1°C
SW4-2(J2)	ON	With abnormality resetting
	OFF	Without abnormality resetting
SW4-3(J3)	ON	4 position louver control: valid
	OFF	4 position louver control: invalid
SW5-1(J4)	ON	1 Phase model
	OFF	3 Phase model
SW5-2(J5)	ON	Step input
	OFF	Pulse input

- (ii) Please match the settings of control switching switches (SW3, SW4, SW5) to the settings they had before they were replaced. With these switches, if the printed circuit had a jumper wire before being replaced, set to jumper wire ON if there was a jumper wire and jumper OFF if these was not.

- (iii) Connect the fast-on terminals and connectors that are to the circuit board for the micro-computer.

Connect by matching the wire color of the fast-on terminal with the color printed on the circuit board for the micro-computer.

Note (1) When connecting to the fast-on connection for the circuit board for the micro-computer, use care so as not to excessively distort the circuit board.

(c) Inspection method when there are fault lamps (display lamps on indoor unit).

(i) Only case of wireless remote control model

1 Defective indoor unit heat exchanger thermistor

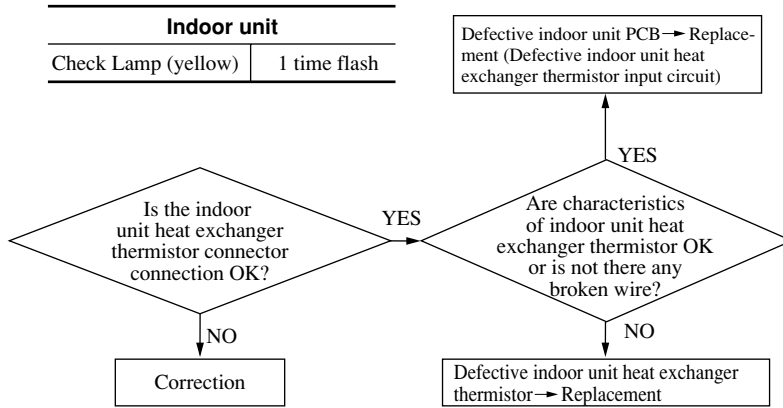

Return air thermistor (Th_rA)
Indoor unit heat exchanger thermistor (Th_rR)
Resistance temperature characteristics

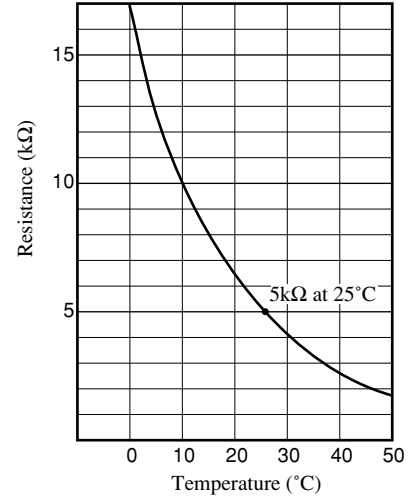

Note (1) 22.5 kΩ at -6°C

2 Defective return air thermistor

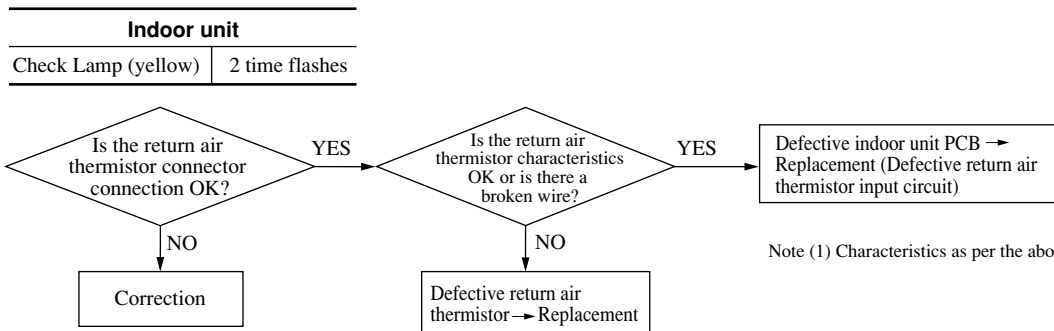

Note (1) Characteristics as per the above graph.

3 Drain abnormality

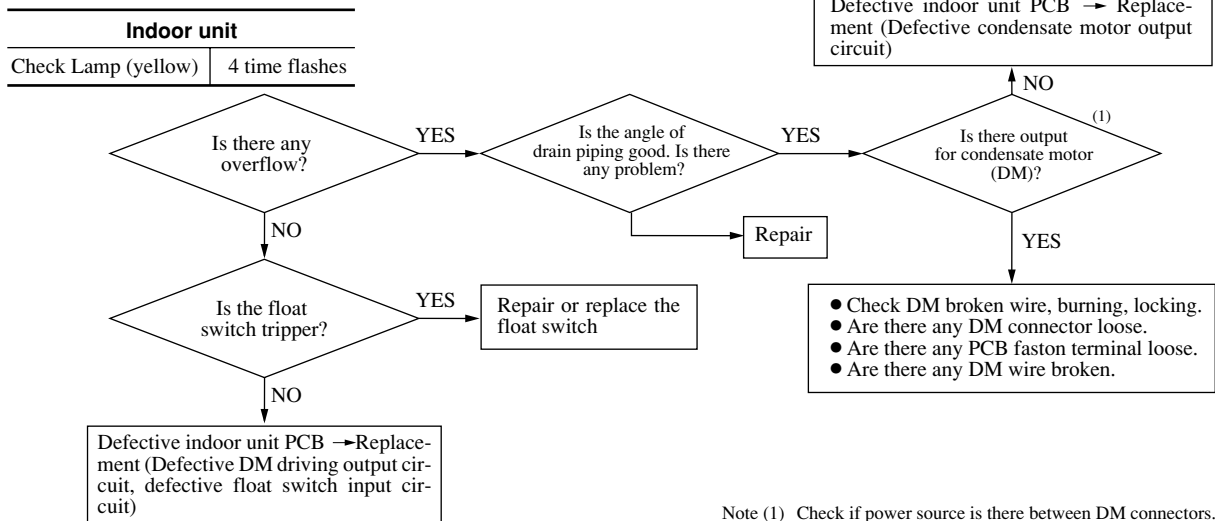

Note (1) Check if power source is there between DM connectors.

4 Abnormality casued by insufficient refrigerant.

Indoor unit	
Check Lamp (yellow)	5 time flashes

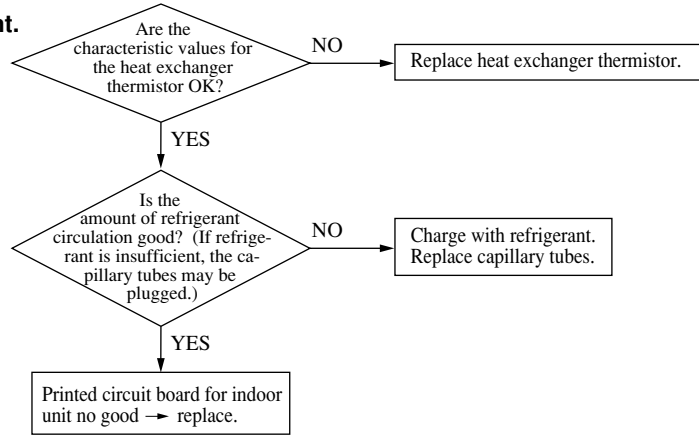

Note (1) Refer to previous page for heat exchanger thermistor temperature resistance characteristic values.

5 Heating overload

Indoor unit	
Check Lamp (yellow)	6 time flashes

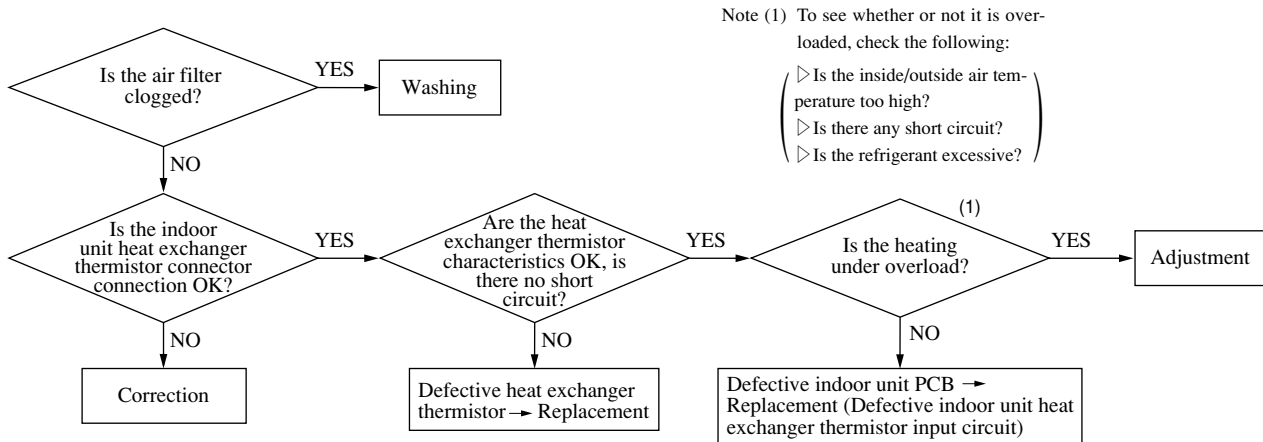

(ii) Only case of wired remote control model

1 Error display : E1 [Communication error between control switch ~ Indoor unit PCB]

- Normal voltage for control switch wiring (DC)
 - Between X and Z : 10.5 ~ 10.8 V
 - Between Y and Z : 5 ~ 10.8 V

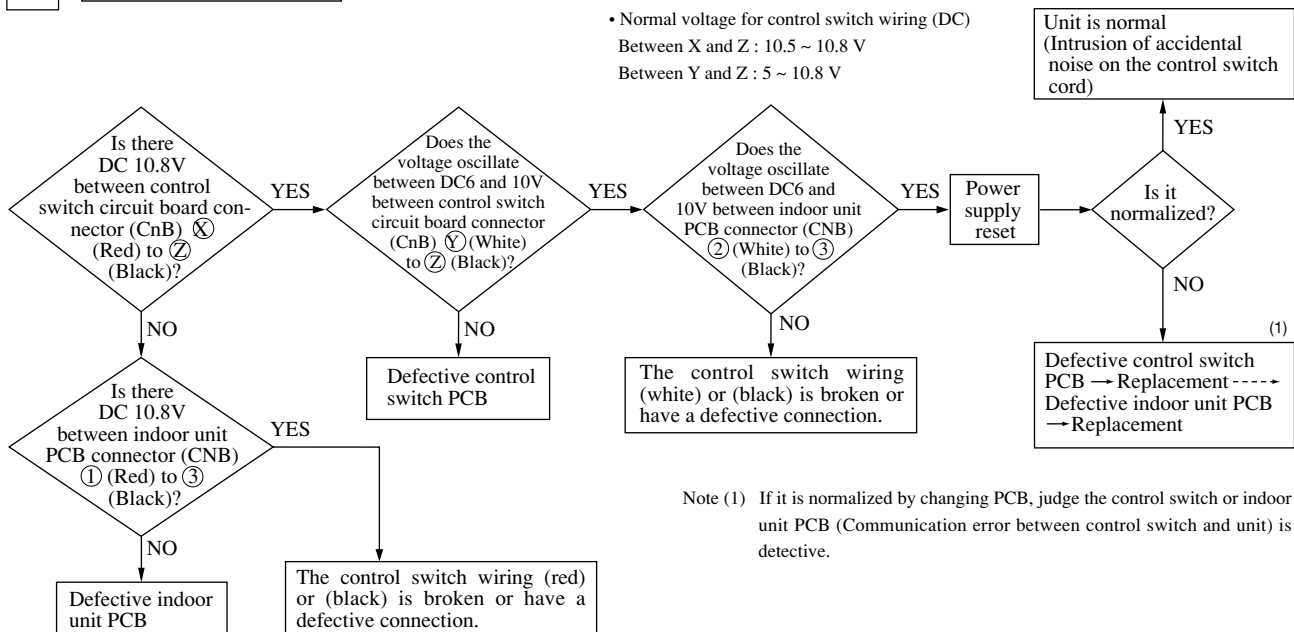

2

Error display : **E6**

[Defective indoor unit heat exchanger thermistor]

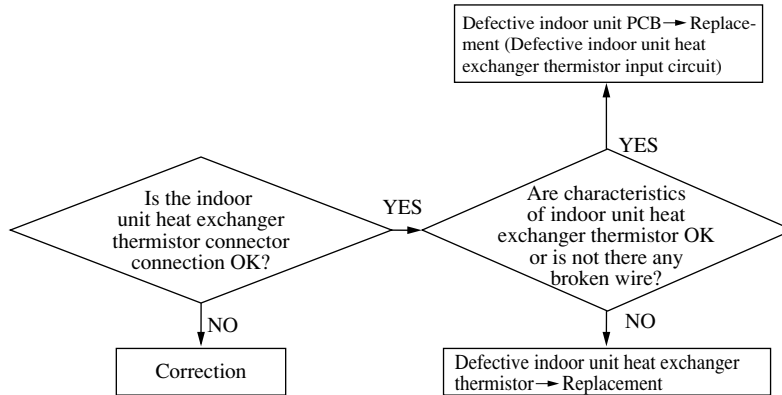

Return air thermistor (Th-A)
Indoor unit heat exchanger thermistor (Th-R)
Resistance temperature characteristics

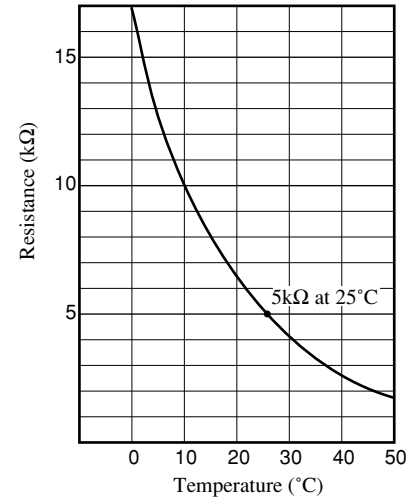

Note (1) 22.5 kΩ at -6°C

3

Error display : **E7**

[Defective return air thermistor]

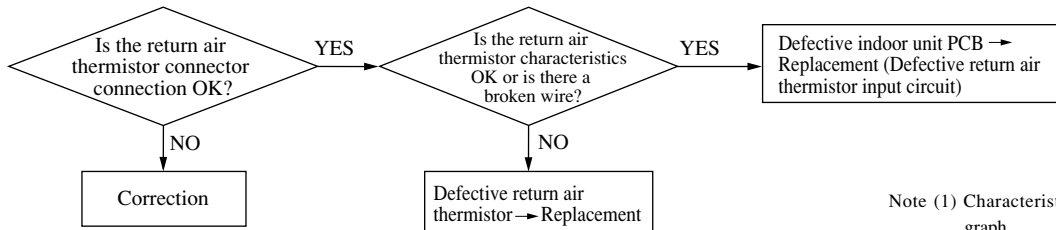

Note (1) Characteristics as per the above graph.

4

Error display : **E8**

[Heating overload]

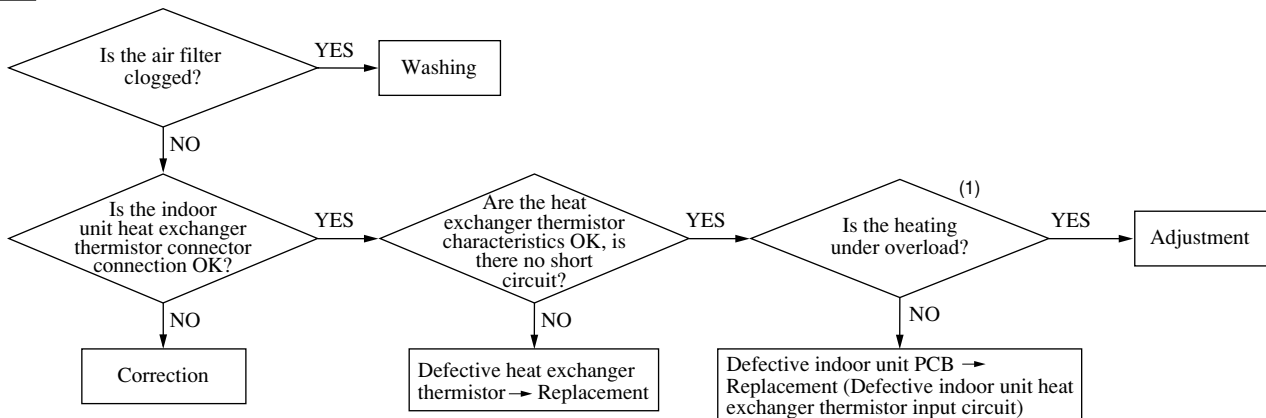

Note (1) To see whether or not it is overloaded, check the following:

- ▶ Is the inside/outside air temperature too high?
- ▶ Is there any short circuit?
- ▶ Is the refrigerant excessive?

5 **Error display : E9** [Failure in drainage]

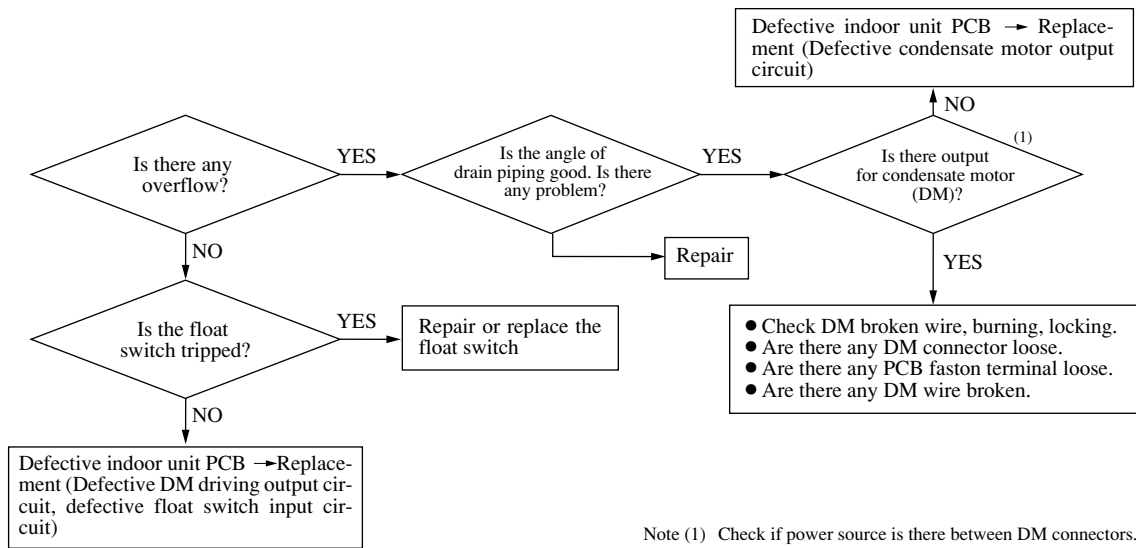

6 **Error display : E10** [1 Remote controller for multiple unit control ⇨ Exceeding connected units (17 units or more)]

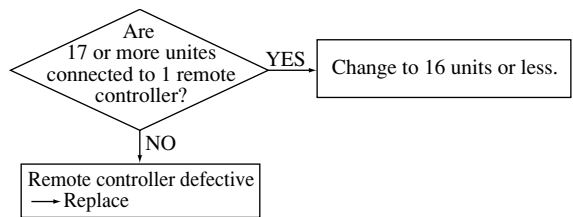

7 **Error display : E57** [Insufficient refrigerant]

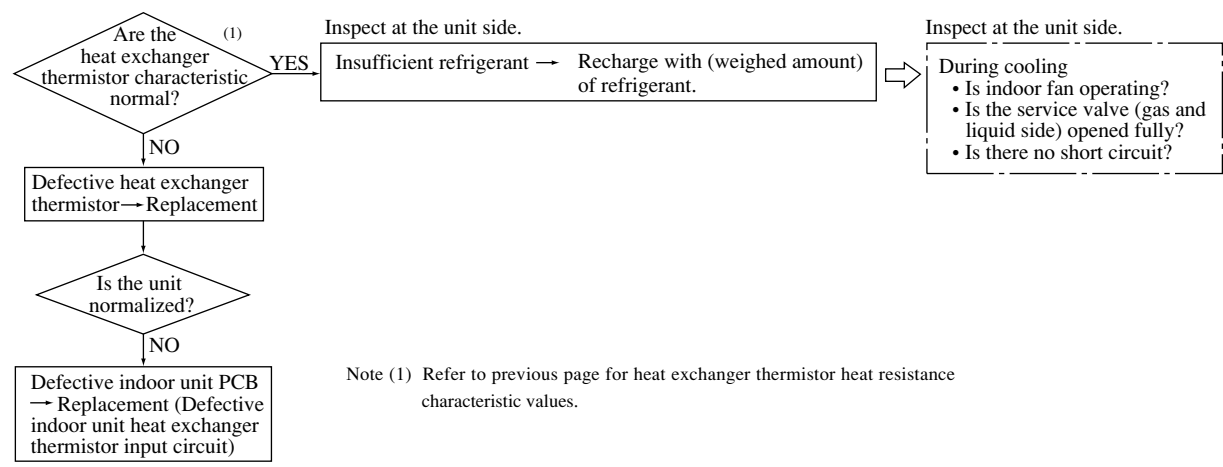

(4) Outdoor unit side (FDC(P)208~508 type, FDC808, 1008 type)

Check Indicator Table

Failure mode on the outdoor unit is indicated by flashing both Green LED (LED-G) and Red LED (LED-R) on the printed circuit board.

Outdoor unit LED		Failure at:	Contents of the failure
Green	Red		
Keeps flashing	Stays OFF	—————	Normal/Power is supplied.
Stays OFF	1 time flash	Power wiring	<ul style="list-style-type: none"> The outdoor power wiring is in reversed phase. Open phase at L3 phase (primary side). Incorrect set-up of outdoor unit PCB.
Stays OFF	2 time flashes	Installation or operation status	<ul style="list-style-type: none"> Over current of the compressor motor. Open phase at L2 phase (secondary wiring of 52C) of compressor. Defective outdoor unit PCB.
Stays OFF	3 time flashes	CM wiring	<ul style="list-style-type: none"> The wiring (secondary wiring of 52C) to the compressor is open.
Stays OFF	4 time flashes	Installation or operation status	<ul style="list-style-type: none"> The outdoor heat exchanger temperature is too high [70°C or over].
		Outdoor heat exchanger thermistor	<ul style="list-style-type: none"> Failure with the outdoor heat exchanger thermistor.
Stays OFF	5 time flashes	Installation or operation status	<ul style="list-style-type: none"> The discharge gas temperature is too high.
		Discharge gas thermistor	<ul style="list-style-type: none"> Failure with the discharge gas thermistor.
1 time flash	1 time flash	Outdoor heat exchanger thermistor	<ul style="list-style-type: none"> Failure or open circuit with the outdoor heat exchanger thermistor or imperfect connection of the connector.
1 time flash	2 time flashes	Outdoor temperature thermistor	<ul style="list-style-type: none"> Failure or open circuit with the outdoor temperature thermistor or imperfect connection of the connector.
1 time flash	3 time flashes	Discharge gas thermistor	<ul style="list-style-type: none"> Failure with the discharge gas thermistor or imperfect connection of the connector.
1 time flash	4 time flashes	Installation or operation status	<ul style="list-style-type: none"> The high pressure is too high or it went up (63H1, 49C).
1 time flash	5 time flashes	Failure to open the service valve	<ul style="list-style-type: none"> Closing of the service valve on the liquid/gas side.

“Check Indicator” is reset when power supply is turned off once and the failure is fixed.

(a) Procedure for diagnosing trouble for outdoor unit

When diagnosing trouble for the outdoor unit, check the flashing and turns of the inspection indicator lamp (red LED) and fault indicator lamp (green LED) to obtain a general concept of the nature of the problem. Then inspect and perform repair.

1) Unit replacement parts related to printed circuit board for outdoor unit.

Micro-computer for outdoor unit, microcomputer, printed circuit board, thermistor (heat exchanger, discharge piping and outdoor air), fuses and transformer.

2) Summary of replacement for micro-computer for outdoor unit

a) Check the following part number

Model	Parts No.	Model	Parts No.	Model	Parts No.
1 phase model	PCA505A046ZN	3 phase model	PCA505A046ZS	FDC808, 1008 model	PCA505A046ZC

b) Set the overcurrent value using the overcurrent setting switch (SW3) for CM. Refer to the following table at the setting.

• Table of switch (SW3) setting

Model	FDC208HEN3A FDCP208HEN3A	FDC258HEN3A FDCP258HEN3A	FDC308HEN3 FDCP308HEN3	FDC308HES3 FDCP308HES3	FDC408HES3 FDCP408HES3	FDC508HES3 FDCP508HES3	FDC808HES3	FDC1008HES3
Setting value (A)	12	15	23	9	12	15	24	34
Table of switch setting Make ON/OFF setting for each switch No. (■ : ON, □ : OFF)								

Parts layout on the outdoor unit PCB

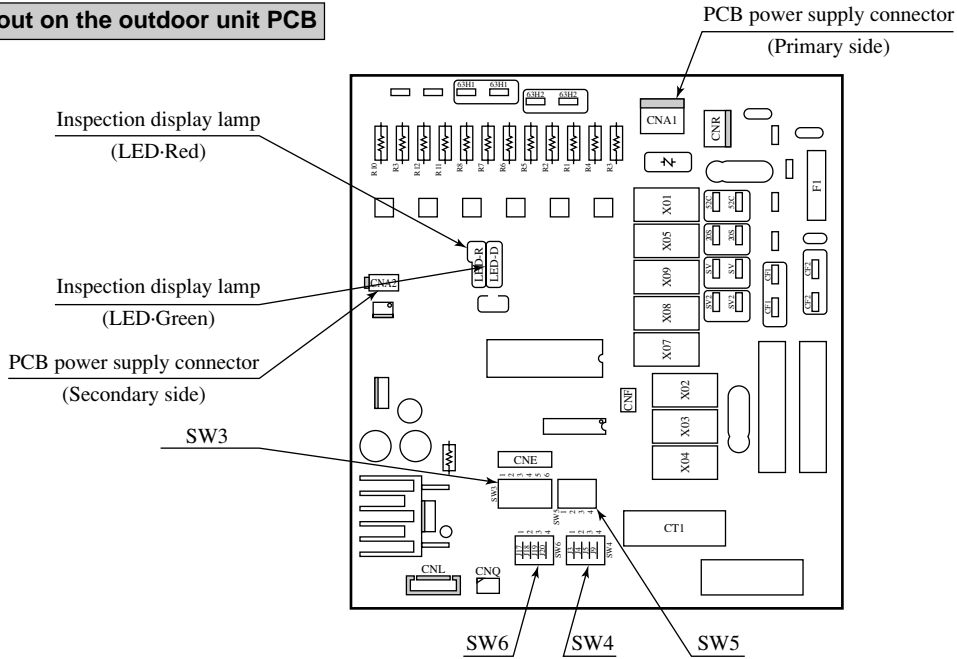

• Function of DIP switched (SW4)

SW4				Function	
1 (J3)			ON	1 Phase model	
			OFF	3 Phase model	
2 (J4)	ON	3 (J5)	ON	Compressor unit switching	—
			OFF		Rotary
	ON		Reciprocal		
	OFF		Scroll		
4 (J9)			ON	Spare	
			OFF		

• Function of DIP switched (SW5)

SW5		Function	
1	ON	Defrost Switching	Actual spot
	OFF		Ordinary
2	ON	Snow protection control	Enabled
	OFF		Disabled
3	ON	Test run Switch	Test run
	OFF		Normal
4	ON		Test run for heating
	OFF		Test run for cooling

• Function of DIP switched (SW6)

SW6		Function	
1 (J17)	ON	4-Way Valve Control	Enabled
	OFF		Disabled
2 (J18)	ON	Defrost Circulation	14°C
	OFF	Temperature Switching	18°C
3 (J19)	ON	63HI Abnormal detection switching	Enabled
	OFF		Disabled
4 (J20)	ON	3 minute delay when power is turned on Switching	Enabled
	OFF		Disabled

• Function of jumper wire

Name		Function
J21	With	Service valve open/close check control enabled.
	None	Service valve open/close check control disabled.

(b) Inspection method when there are fault lamps (outdoor unit LED)

1 Open phase at L₃ phase (Primary side)

Outdoor unit	
Red LED	1 time flash
Green LED	Stays OFF

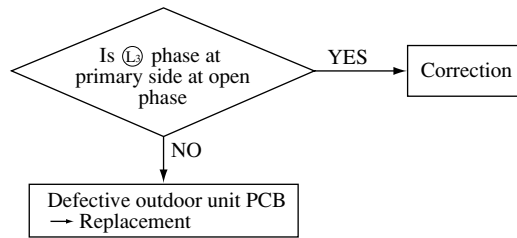

2 Overcurrent of the compressor motor

Outdoor unit	
Red LED	2 time flashes
Green LED	Stays OFF

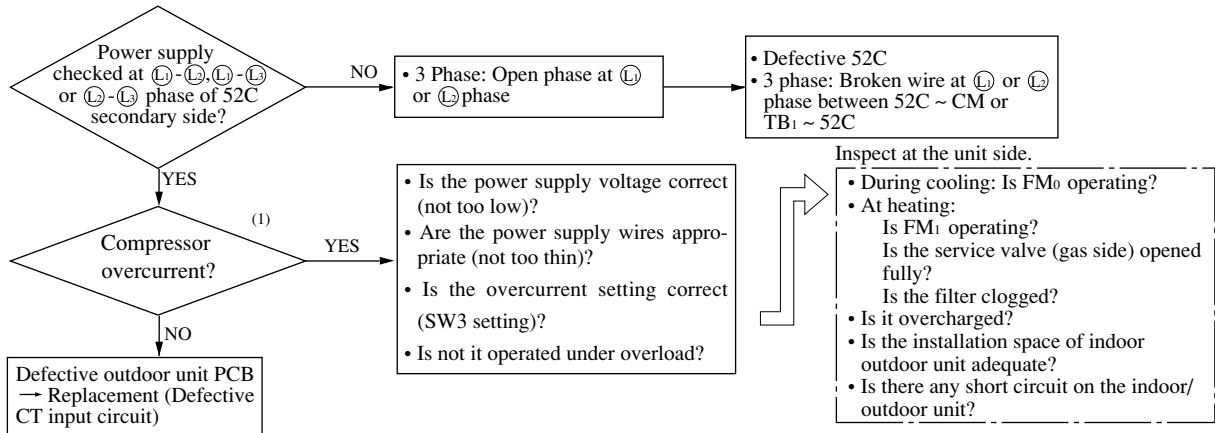

Note (1) Measure and check the current value.
Confirm that the overcurrent setting by SW₃ of outdoor unit PCB is correct.

3 The wiring (secondary wiring of 52C) to the compressor is open.

Outdoor unit	
Red LED	3 time flashes
Green LED	Stays OFF

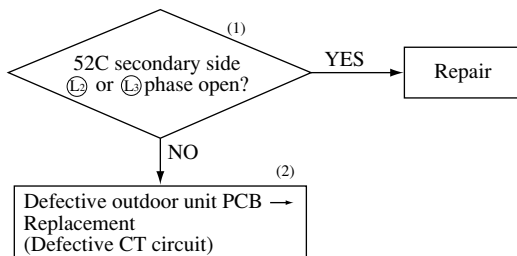

Notes (1) When voltage is detected at 52C primary side L₁ or L₂ phase but not at the secondary side, check also 52C (broken coil, poor contact).
(2) When voltage is detected at 52C primary side L₁ or L₂ phase and there is no error at 52C (52C is energized if TB₁ L₁ or L₂ terminal and 52C coil secondary side connector are short circuited), the outdoor unit PCB (defective X₀₁ circuit or X₀₁) or indoor unit PCB (defective thermostat circuit) is defective.

4 The outdoor heat exchanger temperature is too high (70°C or over)

Outdoor unit	
Red LED	4 time flashes
Green LED	Stays OFF

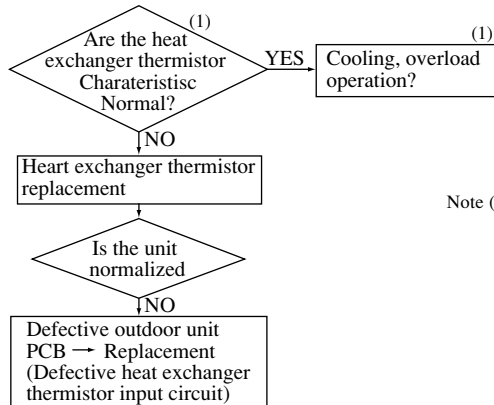

Check the unit side closely

- Is outdoor fan motor operating?
- Is the outdoor unit shortcircuited?
- Is the installation space adequate?
- Is there too much refrigerant?

Note (1) Outdoor unit heat exchanger thermistor detects the state of cooling overload operation.

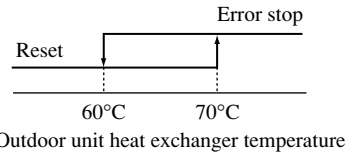

5 The discharge gas temperature is too high. (Only case of FDC(P)208-508 type)

Outdoor unit	
Red LED	5 time flashes
Green LED	Stays OFF

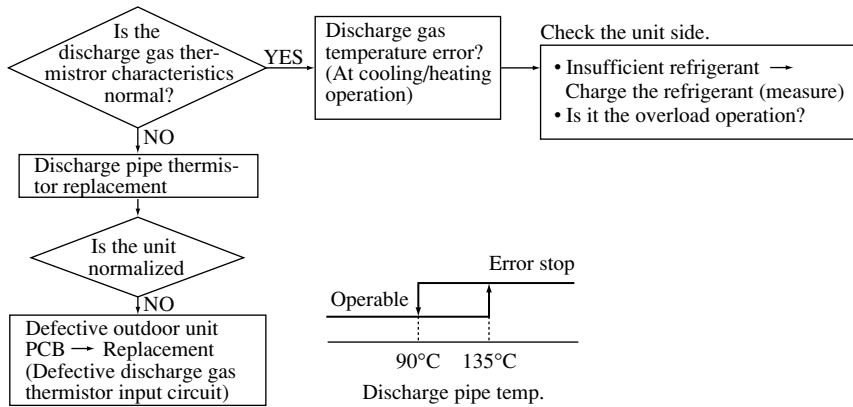

Check the unit side.

- During cooling: Is FMO operating?
- During heating: Is FM_H operating?
- Are control valves (both liquid, gas) fully opened during both cooling and heating.
- Is the installation space of indoor/outdoor units adequate?
- Is there any short circuit air flow for indoor/outdoor units?

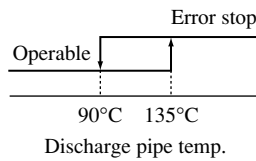

6 Defective outdoor unit heat exchanger thermistor

Outdoor unit	
Red LED	1 time flash
Green LED	1 time flash

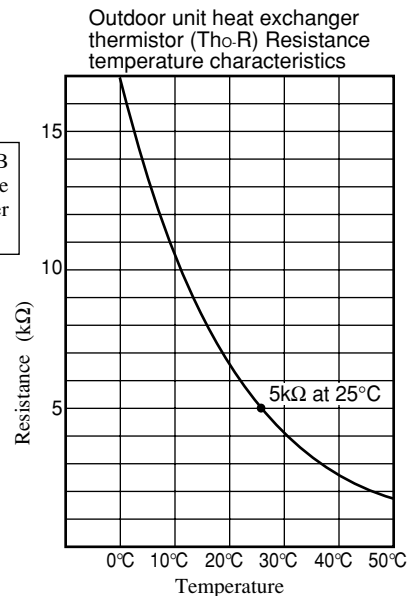
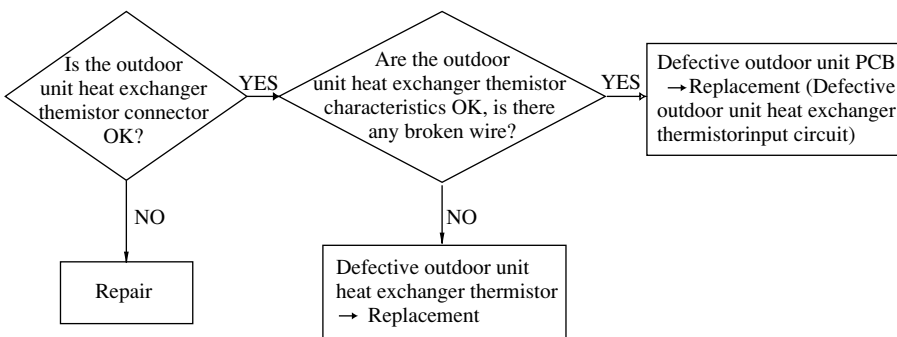

Note (1) 22kΩ at -6°C

7 Defective outdoor temperature thermistor

Outdoor unit	
Red LED	2 time flashes
Green LED	1 time flash

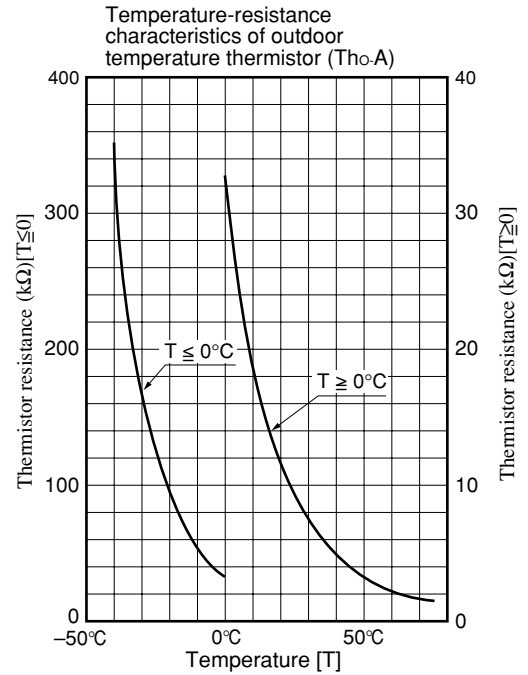
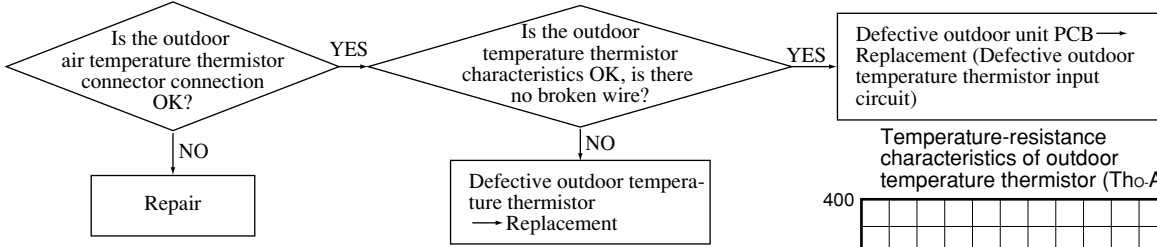

8 Defective discharge gas thermistor (Only case of FDC(P)208~508 type)

Outdoor unit	
Red LED	3 time flashes
Green LED	1 time flash

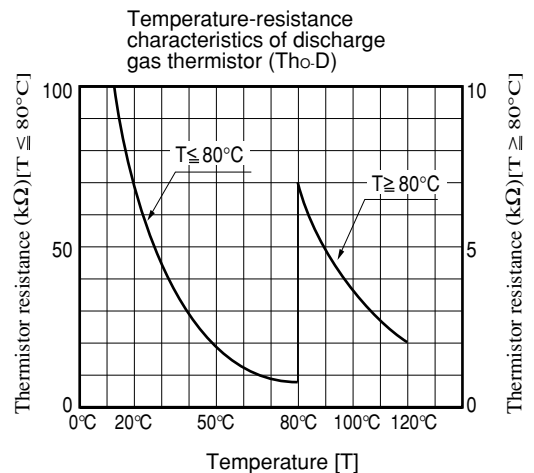
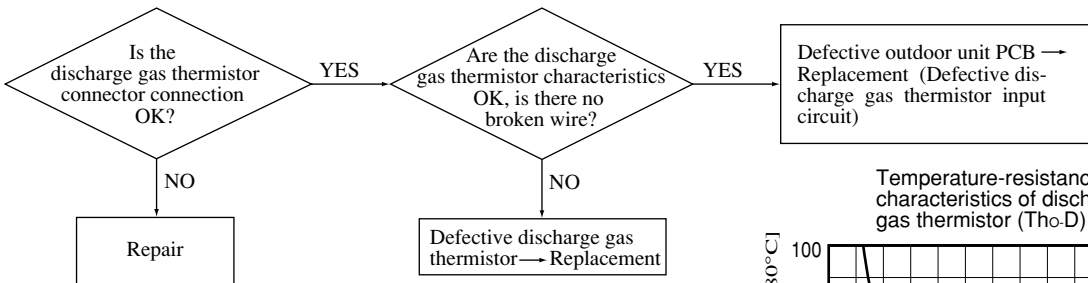

9 High pressure error [63H1] (Only case of FDCP208~508 type)

Outdoor unit	
Red LED	4 time flashes
Green LED	1 time flash

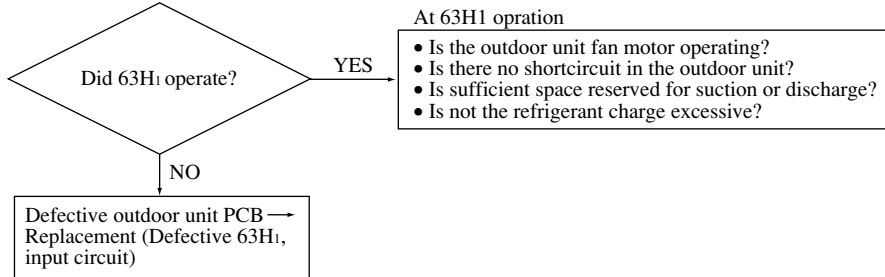

63H1, 49C operation (Only case of FDC808, 1008 type)

Outdoor unit	
Red LED	4 time flashes
Green LED	1 time flash

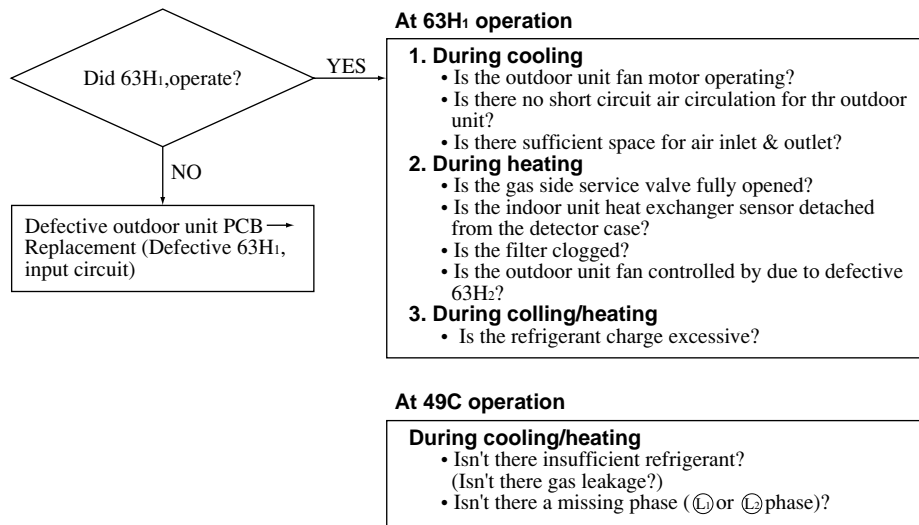

10 Failure to open the service valve

Outdoor unit	
Red LED	5 time flashes
Green LED	1 time flash

This abnormality will be indicated only when the compressor is ON for the time after turning on the power. (Refer to page 331)



MITSUBISHI
HEAVY INDUSTRIES, LTD.

AIR CONDITIONING AND HEAT PUMP SYSTEMS

NOTICE

The installation of this equipment must comply with all **NATIONAL, STATE and LOCAL CODES.**

This Service Guide does not cover all installation circumstances and is meant for guidance only and therefore will not form part of any legally binding contract. An installation guide is provided with the air conditioning equipment.

CE

This Air Conditioner complies with: -
EMC Directive 89/336/EEC
LV Directive 73/23/EEC

3D Air Sales Ltd

Sales & Marketing Office

850 Brighton Road,
Purley, Surrey, CR8 2BH
Telephone: 020 8668 1112
Facsimile: 020 8668 1113

3D Air Sales Ltd

Warehouse, Sales Admin., Spares, Warranty

Anglia House, Priors Way,
Coggeshall, Essex, CO6 1TL
Telephone: 01376 565 505
Facsimile: 01376 565 525

3D Air Sales (Ireland) Ltd

Unit 21, Western Industrial Estate,
Nass Road, Dublin12, Ireland
Telephone: 01 450 9433
Facsimile: 01 450 9799

3D Air Sales Ltd

Scottish Sales Office

McGregor House, Southbank Business Park,
Kirkintilloch, Glasgow, G66 1XF
Telephone: 0141 777 5007
Facsimile: 0141 777 5009