



**ecolution**  
AIR CONDITIONING

# FDCVA INVERTER Multi Systems

FDCVA

Mitsubishi Heavy Industries has further extended its development in world leading technology applied to high efficiency air conditioning and heat pump systems

## FDCVA INVERTER Multi Systems

Cooling Range: 8.0 - 28kW

Heating Range: 9.0 - 31.5kW



Ideal for cooling and heating open plan areas from 20m<sup>2</sup> to 600m<sup>2</sup>



FITNESS GYMS • RETAIL STORES • OPEN PLAN OFFICES • CONFERENCE ROOMS • LARGE RESTAURANTS



The ADVANCED FDCVA Multi System is a high specification product, with energy saving INVERTER technology, extended pipe runs, and sophisticated operation and service control functions. The systems are available in TWIN, TRIPLE and QUAD format.

- Simple operation - all units on a system are connected to one controller and will operate in the same mode ie. cooling, heating or fan only
- 7-day/24-hr Programmable Timer - included in standard wired controller
- Mitsubishi INVERTER Scroll Compressors resulting in significant savings in running costs
- Up to 70m pipe runs
- Compact Outdoor Units with side-blow fans, have now been introduced, with lower sound levels and smaller physical size, ideal for installation in restricted locations

**Wiring Arrangement and Master/Slave settings for Multi Systems**

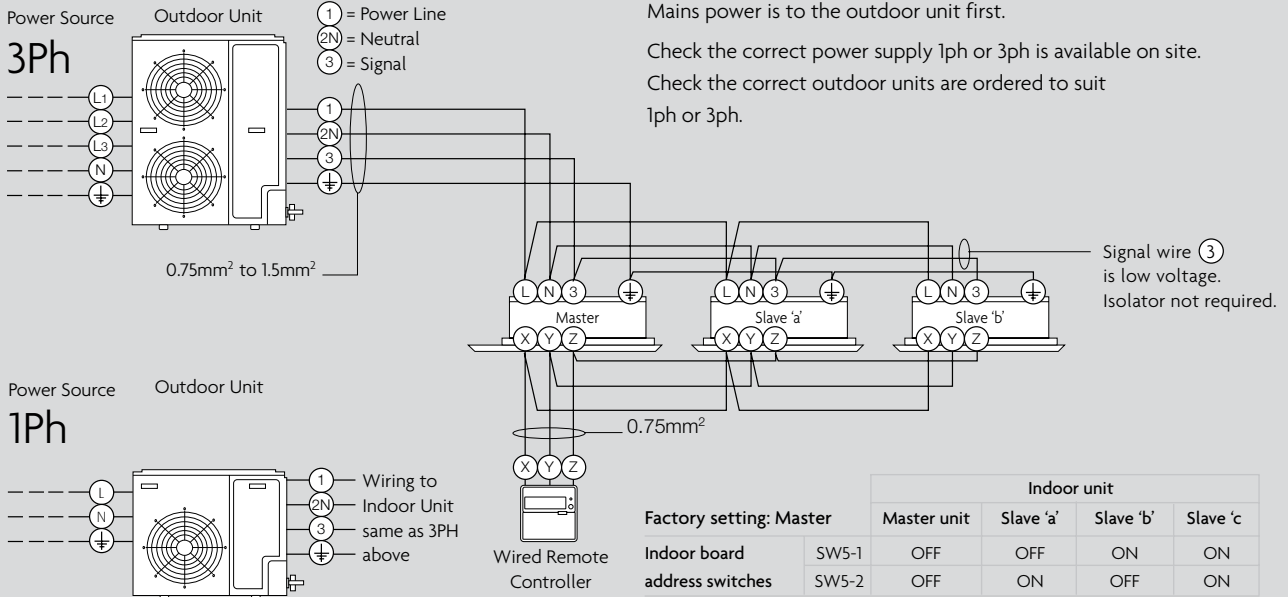

**Power Supplies & Operating Current - Outdoor Units**

Outdoor Unit	Power Supply Outdoor Unit	Operating to Current (c/g.)
FDCVA302HEN	16A	9.8A
FDCVA402HEN	1ph 20A	12.3A
FDCVA502HEN	1ph 25A	18.3A
FDCVA602HEN	1ph 30A	20.4A
FDCVA802HES	3ph 15A/ph	9.1A/ph
FDCVA1002HES	3ph 20A/ph	12.7A/ph

**Indoor Unit Address**

Indoor units connected to FDA Multi Systems are required to be addressed, to enable the controls to recognise which units are connected to each system. Each system comprises one master indoor unit and one, two or three slave indoor units.

**Indoor Units - Operating Current**

Indoor Unit	FDT	FDE	FDUM	FDK
151	0.3A	0.2A		0.2A
201	0.3A	0.2A	0.9A	0.2A
251	0.3A	0.4A	1.0A	0.2A
301	0.3A	0.4A	1.3A	
401	0.6A	0.5A	1.7A	
501	0.7A	0.6A	2.0A	

**Group Control**

Where Multi Systems are controlled on a Group arrangement (up to 16 systems) using a single remote controller, it is necessary to adjust SW2 so each individual Multi System has indoor units with the same address number, ie. 0-0-0, 1-1-1, 2-2-2, etc.

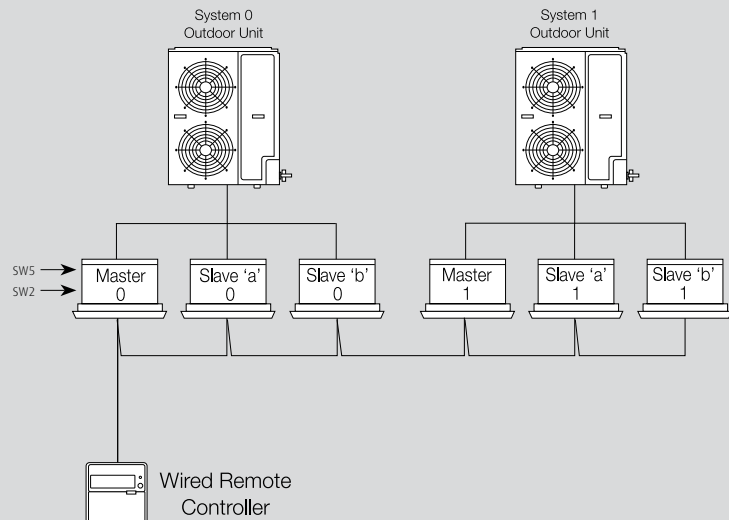

The Master/Slave addresses must also be adjusted using SW5 - see above



## Pipe Length Limitations

### Height Difference (all systems)

Outdoor unit above max. height difference is 30m  
 Outdoor unit below max. height difference is 15m  
 Difference between indoor units max. height difference is 0.5m

### Twin Systems 8.0kW to 14.3kW

A = main piping, B = branch piping, C = branch piping

A + B + C	Maximum is	50 metres
Difference between B & C	No more than	10 metres
B	Maximum is	20 metres
C	Maximum is	20 metres

### Triple Systems 14.3kW

A + B + C + D	Maximum is	50 metres
Difference between B & C or C & D	No more than	10 metres
B	Maximum is	20 metres
C	Maximum is	20 metres
D	Maximum is	20 metres

### Twin Systems 22.4 & 28.0 kW – FDCA802 & 1002

Outdoor unit to furthest indoor unit	Maximum is	70 metres
Difference between B & C	no more than	10 metres
B	Maximum is	30 metres
C	Maximum is	30 metres

### Triple Systems 22.4 & 28.0 kW – FDCA802 & 1002

Outdoor unit to furthest indoor unit	Maximum is	70 metres
Difference between B & C & D	no more than	10 metres
B	Maximum is	30 metres
C	Maximum is	30 metres
D	Maximum is	30 metres

### Quad Systems 22.4 & 28.0 kW – FDCA802 & 1002

Outdoor unit to furthest indoor unit	Maximum is	70 metres
Difference between B & C	no more than	10 metres
Difference between D, E, F, G	no more than	10 metres
B + D	Maximum is	30 metres
B + E	Maximum is	30 metres
C + F	Maximum is	30 metres
C + G	Maximum is	30 metres

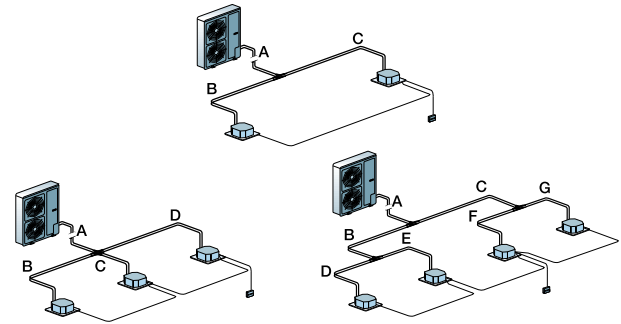

**Refrigerant Pipework** must be installed within limitations detailed in the table. Each system is supplied with the appropriate branch pipe. Pipe connections to the branch kits must be brazed and it is essential to use nitrogen purge while making the connections.

FDCVA 402, 502, 602



FDCVA 802

FDCVA 1002





## Refrigerant Pipe Sizes

Outdoor Unit	Clg/Htg kW	System Type	Pipe sizes o.d(in)			
			A	B	C(&D)	D, E, F, G
FDCVA302HEN	8.0/9.0	TWIN	3/8 5/8	3/8 1/2	3/8 1/2	
FDCVA402HEN	11.2/12.5	TWIN	3/8 5/8	3/8 1/2	3/8 1/2	
FDCVA502HEN	14.0/16.0	TWIN	3/8 5/8	3/8 5/8	3/8 5/8	
FDCVA602HEN	14.8/16.8	TWIN	3/8 5/8	3/8 5/8	3/8 5/8	
FDCVA602HEN	14.8/16.8	TRIPLE	3/8 5/8	3/8 1/2	3/8 1/2	
FDCVA802HES	22.4/25.0	TWIN	3/8 7/8	3/8 5/8	3/8 5/8	
FDCVA802HES	22.4/25.0	TRIPLE	3/8 7/8	3/8 5/8	3/8 5/8	
FDCVA802HES	22.4/25.0	QUAD	3/8 7/8	3/8 5/8	3/8 5/8	3/8 1/2
FDCVA1002HES	28.0/31.5	TWIN	1/2 7/8	3/8 5/8	3/8 5/8	
FDCVA1002HES	28.0/31.5	TRIPLE	1/2 7/8	3/8 5/8	3/8 5/8*	
FDCVA1002HES	28.0/31.5	QUAD	1/2 7/8	3/8 5/8	3/8 5/8	3/8 5/8

\*For 201/401/401 (indoors) Triple, use 3/8 & 1/2 for the 201 connection

## Outdoor Unit Dimensions & Weights

mm	H	W	D	Kg
FDC/FDCVA302	750	970	340	60
FDC/FDCVA402	845	970	370	63
FDC/FDCVA502	845	970	370	63
FDC/FDCVA602	845	970	370	63
FDC/FDCVA802	1300	970	370	122
FDC/FDCVA1002	1505	970	370	140

SYSTEM REFERENCE INCLUDES: Outdoor Unit + Indoor Units + One Remote Controller, + Pipe Kit					FDTA	FTCA	FDEA	FDUMA	FDKA
					CASSETTE	COMPACT CASSETTE	CEILING MOUNTED	DUCTED	WALL MOUNTED
OUTDOOR UNIT INVERTER		INDOOR UNIT							
OUTDOOR UNIT	COOLING range kW	HEATING range kW	Power supply	REF:	INVERTER	INVERTER	INVERTER	INVERTER	INVERTER
FDCVA	3.2 to 8.0	3.6 to 9.0	1 ph 16A	2 x 151	M2FDTVA151HEN	M2FDTCVA151HEN	M2FDEVA151HEN	FDUMA units include discharge spigots & condensate lift pump.	M2FDKVA151HEN
302HEN	TWIN								
FDCVA	6.1 to 11.2	5.8 to 12.5	1 ph* 20A	2 x 201	M2FDTVA201HEN	M2FDTCVA201HEN	M2FDEVA201HEN	M2FDUMVA201HEN	M2FDKVA201HEN
402HEN	TWIN								
FDCVA	6.5 to 14.0	6.2 to 16.0	1 ph* 25A	2 x 251	M2FDTVA251HEN	N/A	M2FDEVA251HEN	M2FDUMVA251HEN	M2FDKVA251HEN
502HEN	TWIN								
FDCVA 602HEN	6.7 to 14.8	6.3 to 16.8	1 ph* 30A	2 x 301	M2FDTVA301HEN	N/A	M2FDEVA301HEN	M2FDUMVA301HEN	N/A
	TWIN								
FDCVA 602HEN	6.7 to 14.8	6.3 to 16.8	1 ph* 30A	3 x 201	M3FDTVA201HEN	M3FDTCVA201HEN	M3FDEVA201HEN	M3FDUMVA201HEN	M3FDKVA201HEN
	TRIPLE								
FDCVA 802HES	7.0 to 22.4	7.6 to 25.0	3 ph 15A/ph	2 x 401	M2FDTVA401HES	N/A	M2FDEVA401HES	M2FDUMVA401HES	N/A
	TWIN								
	7.0 to 22.4	7.6 to 25.0	3 ph 15A/ph	3 x 301	M3FDTVA301HES	N/A	M3FDEVA301HES	M3FDUMVA301HES	N/A
	TRIPLE								
7.0 to 22.4	7.6 to 25.0	3 ph 15A/ph	4 x 201	M4FDTVA201HES	M4FDTCVA201HES	M4FDEVA201HES	M4FDUMVA201HES	M4FDKVA201HES	
QUAD									
FDCVA 1002HES	10.6 to 28.0	9.5 to 31.5	3 ph 20A/ph	2 x 501	M2FDTVA501HES	N/A	M2FDEVA501HES	M2FDUMVA501HES	N/A
	TWIN								
	10.6 to 28.0	9.5 to 31.5	3 ph 20A/ph	2 x 301 1 x 401	M3FDTVA301401HES	N/A	M3FDEVA301401HES	M3FDUMVA301401HES	N/A
	TRIPLE								
10.6 to 28.0	9.5 to 31.5	3 ph 20A/ph	4 x 251	M4FDTVA251HES	N/A	M4FDEVA251HES	M4FDUMVA251HES	M4FDKVA251HES	
QUAD									

Cooling Nom: 27°Cdb/19°Cwb, Amb: 35°C UK Cooling: l/d: 23°Cdb/16°Cwb, Amb: 30°C Heating: l/d: 20°Cdb, Amb: 7°Cdb/6°Cwb

\*3PH UNITS ALSO AVAILABLE 402, 502 & 602

N.B. FDKA301 Wall mounted indoor unit is now discontinued

MULTI SYSTEMS have all indoor units operating in the same mode (cool or heat) at the same time. They are ideal for open plan areas, such as large offices, retail shops and stores, fitness gyms, conference halls. They are not suitable for indoor units to be installed in separate rooms. Use the new KX INVERTER Multi Systems for these applications.

COOLING & HEATING capacities listed above are for guidance, and are based on nominal ratings. Please refer to technical data for exact cooling & heating values.

MIX-MATCH INDOOR UNITS It is possible to connect Cassette / Ceiling / Ducted on the same Multi System, please call the 3D Sales Office for a quote.

N.B. Wall units are not suitable for mix-match with other indoor styles.